

COMPLETE CC-993 KIT ILLUSTRATED.  
CUT-OUTS IN TRACK TO  
EXPOSE COMPONENTS.

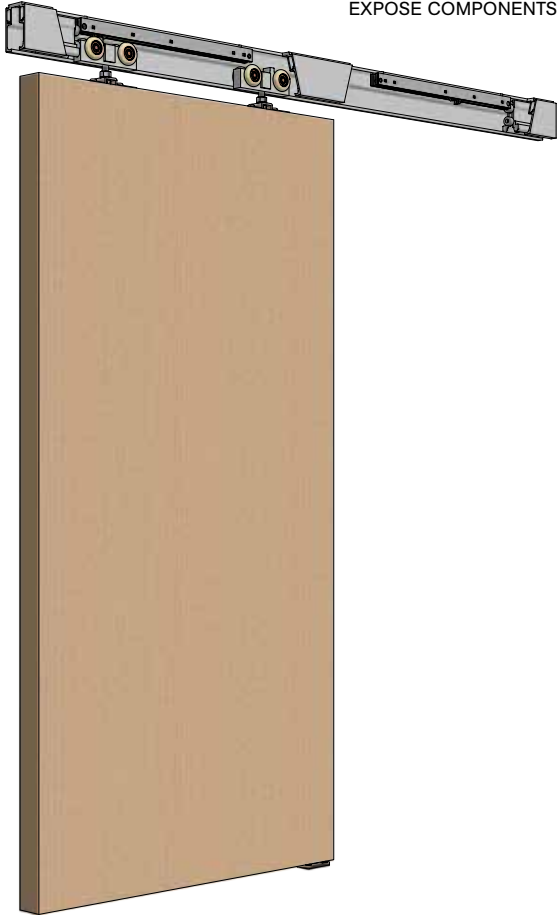

### CROWDERTRACK'S CATCH 'N' CLOSE™ SYSTEM

- PREVENTS BOUNCING AND SLAMMING OF SLIDING DOORS
- CAN BE INSTALLED ON BOTH OPENING AND CLOSING ENDS OF DOORS AS NARROW AS 18 in [457 mm] WIDE
- CYCLE TESTED UP TO 50,000 TIMES
- FOR UP TO 200 lbs. [90 kg] USING CC-993 WITH CC-2

### PARTS LIST - FOR STANDARD CC-993 1DR KIT

- |  |   |   |  |
|--|---|---|--|
|  |   |   |  |
| <p><b>CC-904 TOP MOUNT TRACK X LENGTH (1)</b><br/>LENGTH = 2 X DOOR WIDTH, EXAMPLE:<br/>36 in [914 mm] = 72 in [1829 mm] TRACK</p> |   | <p><b>CC-938 HANGER BODY (2)</b><br/>(c/w WHEELS)</p>     | <p><b>C-AR93 ADJUSTMENT ROD (1)</b></p>                  |
|  |   |   |  |
| <p><b>3/8-16 K-LOCK NUT (2)</b><br/>[FT21]</p>   | <p><b>C-993 EASY CONNECT STUD (2)</b></p>   | <p><b>C-993 TOP PLATE (2)</b></p>                         | <p><b>#10 X 1 1/4" PAN HEAD SCREWS (8)</b><br/>[FT4]</p> |
|  |   |   |  |
| <p><b>#10 X 1 1/2" SELF DRILLING SCREWS (4)</b><br/>[FT5]</p>  | <p><b>CC-2 CATCH 'N' CLOSE CLOSING DEVICE (2)</b><br/>(SEE DETAILS IN INSTRUCTION STEPS)</p>  | <p><b>CC-101HD CATCH 'N' CLOSE IN-TRACK STOPS (2)</b></p> |  |
|  |   |   |  |
| <p><b>CC-913 FLOOR GUIDE (1)</b></p>   | <p><b>C-914 GUIDE CHANNEL X LENGTH (1)</b><br/>(LENGTH = DOOR WIDTH,<br/>EXAMPLE: 36 in [914 mm] DOOR =<br/>36 in [914 mm] GUIDE CHANNEL LESS<br/>SET-BACKS IF DESIRED)</p> | <p><b>#8 X 3/4" PAN HEAD SCREWS (4)</b><br/>[FT2]</p>     |  |
|  |   |   |  |
|  |   | <p><b>#10 X 1 1/2" FLATHEAD SCREWS (2)</b><br/>[FT7]</p>  |  |

### OPTIONAL ADD-ON PRODUCTS

- 
- CC-940 SNAP-ON FASCIA X LENGTH**  
LENGTH = SAME AS TRACK LENGTH, EXAMPLE:  
72 in [1829 mm] = 72 in [1829 mm] FASCIA

- 
- CC-941 END CAPS (LEFT & RIGHT)**

- 
- CC-942 END CAPS (LEFT & RIGHT)**

- 
- CC-943 END CAPS (LEFT & RIGHT)**

- 
- #4 X 5/16" FLAT HEAD SCREWS (FOR END CAPS)**  
[FT29]

# COMPLETE INSTALLATION ELEVATION VIEW

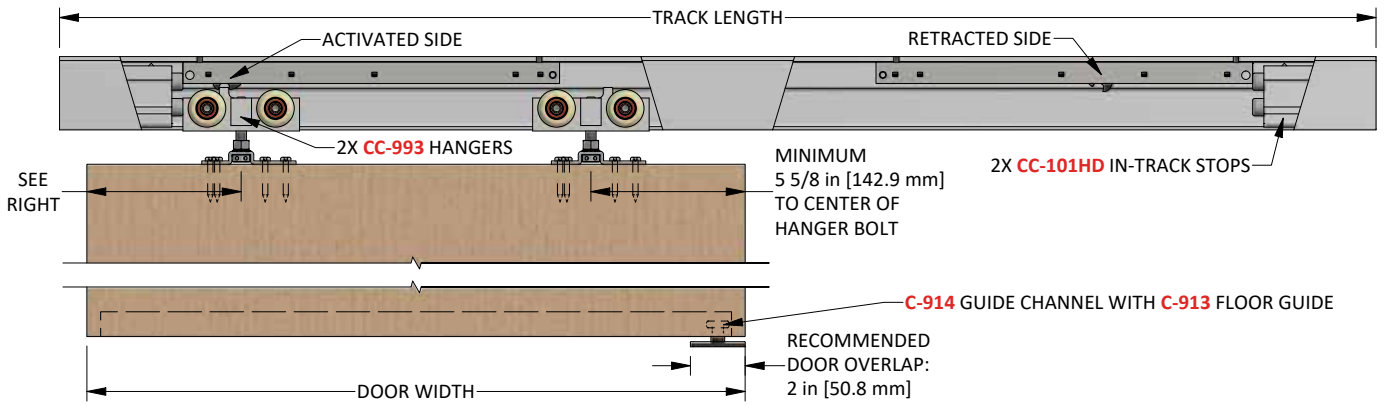

## OPTIONAL CC-940 SNAP-ON FASCIA, ILLUSTRATED AS SOLID BLACK PROFILE

CC-993 KIT DETAILS  
(CC-993 HANGER, CC-904 TRACK, C-914/C-913 GUIDE SYSTEM)

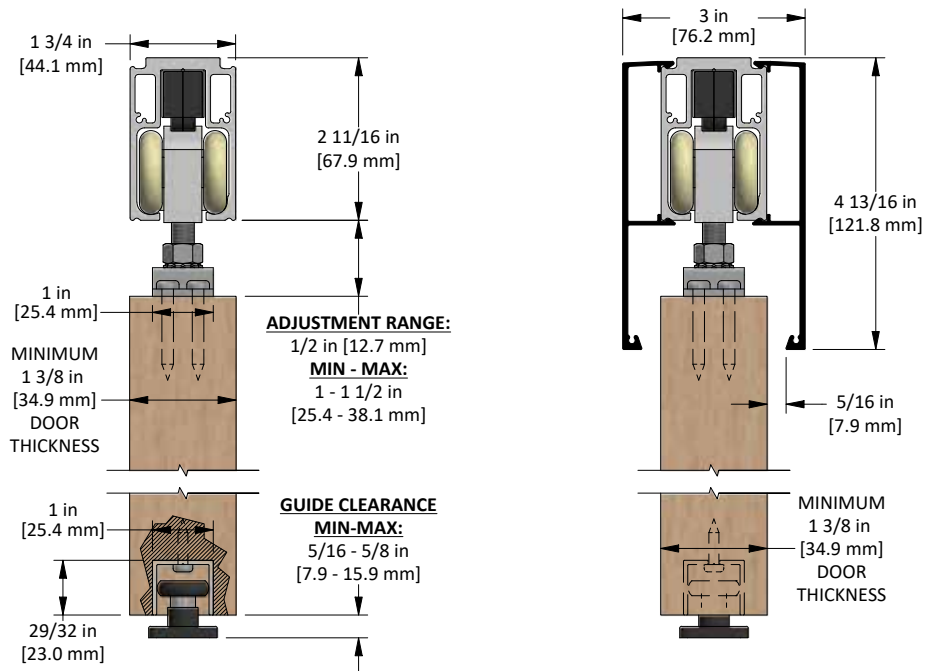

## TYPICAL INSTALLATION LOCATION FOR FLOOR GUIDES: FOR POCKET DOOR APPLICATIONS

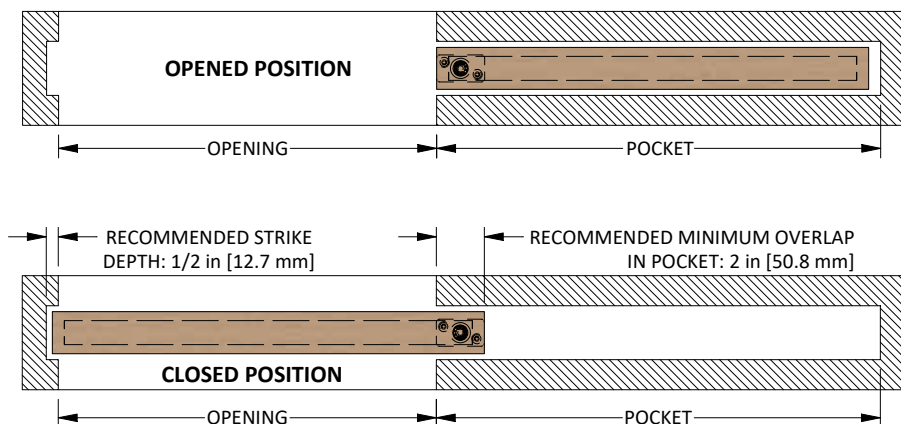

**STEP #1:**

DETERMINE DOOR SIZE, HEADER HEIGHT, TRACK POSITION, AND BOTTOM CLEARANCE BASED ON KIT CODE ORDERED BY USING DIMENSIONS SHOWN IN DETAIL VIEWS ON PREVIOUS PAGE.

**STEP #2:**

**NOTE: IF ACCESS TO THE ENDS OF TRACK IS NOT AVAILABLE, STEPS #3 & 4 MUST BE COMPLETED BEFORE STEP #2.**

CUT CC-904 ALUMINUM TRACK TO SIZE IF REQUIRED (TYPICALLY 2 X THE DOOR WIDTH). LOCATE AND PRE-DRILL HOLES THROUGH THE CENTER OF THE TRACK. SECURE TRACK TO STRUCTURAL SUPPORT/BACKING.

**NOTE: STARTING HOLE LOCATIONS AT EACH END OF TRACK SHOULD BE 1/2 in [12.7 mm] FROM END AND THEN 19 in [482.6 mm] FROM FIRST HOLE. MINIMUM #10 SCREWS OR 1/4 in [6.3 mm] STRUCTURAL BOLTS RECOMMENDED TO SECURE TRACK. SOLID BACKING IS REQUIRED. SPACING IS RECOMMENDED TO BE BETWEEN 12-16 in [304-406 mm] ON CENTER. CONSULT STRUCTURAL ENGINEER TO ENSURE ADEQUATE SUPPORT & FASTENING.**

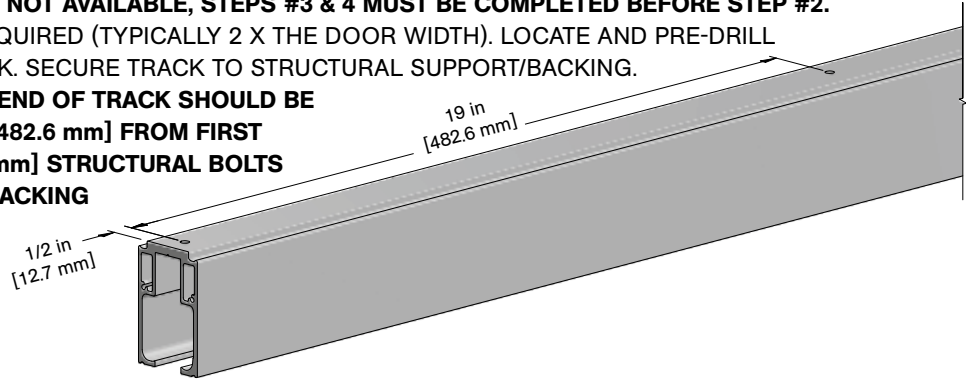

**STEP #3:**

ASSEMBLE CC-993 CATCH 'N' CLOSE HANGERS AS SHOWN BELOW:

**FIG. 1 -** THREAD 3/8-16 K-LOCK NUT [FT21] ONTO C-993 EASY CONNECT STUD WITH LOCK WASHER FACING BOLT HEAD.

**FIG. 2 -** THREAD ASSEMBLY FROM **FIG. 1** INTO CC-938 HANGER BODY FROM UNDERSIDE (SIDE OPPOSITE THE TRIGGER), DO NOT THREAD IN FULLY.

**FIG. 3 -** COMPLETED CC-993 HANGER ASSEMBLY (2 X REQUIRED).

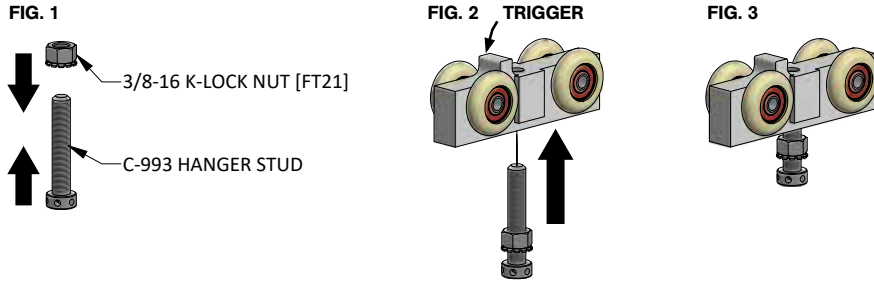

**STEP #4:**

SLIDE ONE (1) CC-993 HANGER ASSEMBLY (\*) WITH TRIGGER FACING END OF TRACK AND ONE (1) CC-101HD IN-TRACK STOP (●) INTO EACH END OF TRACK (AS SHOWN BELOW).

**NOTE: LEAVE SCREWS ON CC-101HD IN TRACK STOPS (●) LOOSE TO ALLOW STOPS TO SLIDE FREELY WITHIN TRACK. RUBBER BUMPERS OF EACH STOP (●) SHOULD FACE INWARD (TOWARD MIDDLE OF TRACK).**

- \* CC-993 HANGER
- CC-101HD IN-TRACK STOPS

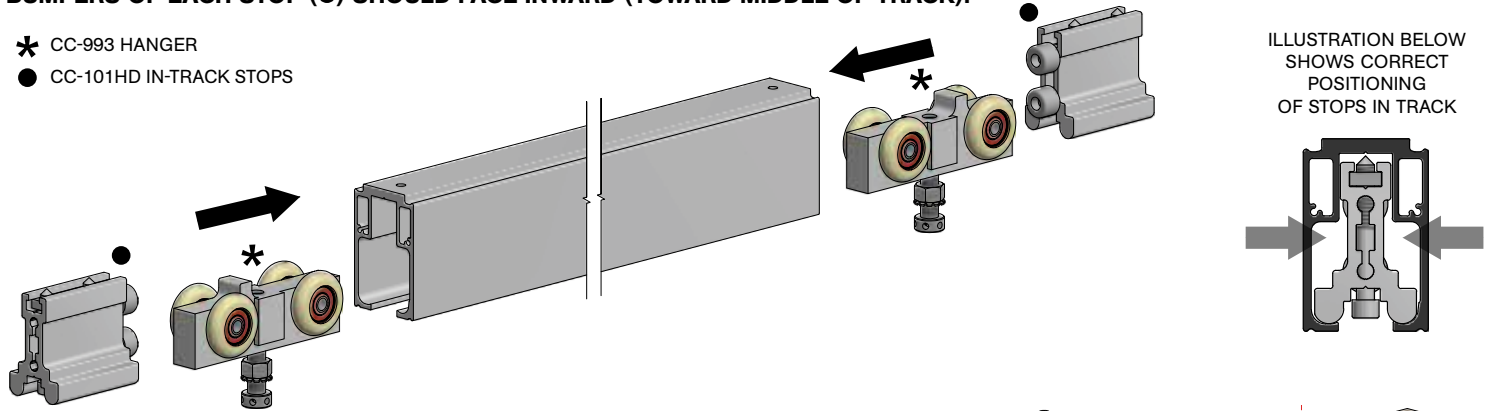

**STEP #5:**

LOCATE CENTER OF "U" SLOT (DASH LINE SHOWN RIGHT) OF C-993 TOP PLATE AT 5 5/8 in [142.9 mm] FROM EACH EDGE OF DOOR (OR SEE TEMPLATE FOR DIMENSIONS FROM EDGE OF DOOR TO LEADING EDGE OF TOP PLATES). MARK SCREW HOLE LOCATIONS OR USE TEMPLATE ON PAGE 8 AND PRE-DRILL Ø1/8 in [3.2 mm] HOLES AT LEAST 1 1/2 in [38.1 mm] DEEP. SECURE C-993 TOP PLATES WITH (4 PER HANGER) #10 X 1 1/4" PAN HEAD SCREWS [FT4]. SEE RIGHT.

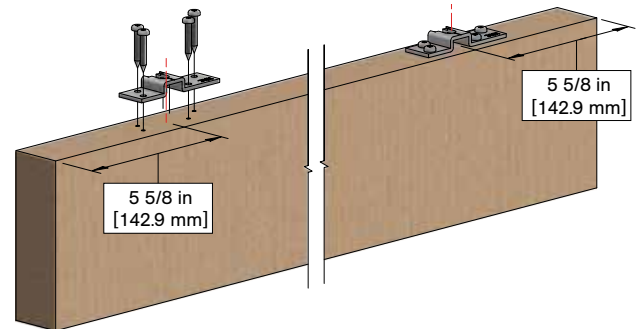

**NOTE:**  
**IF DOOR HAS SUFFICIENT OVERLAP, GUIDE CHANNEL CAN BE RECESSED INTO DOOR WITHOUT CUTTING A FULL-LENGTH SLOT IN DOOR. IF GUIDE CHANNEL WILL BE FULLY RECESSED, IT IS RECOMMENDED TO HAVE AT LEAST 1/2 in [12.7 mm] DOOR MATERIAL AT EACH END OF DOOR BEFORE START OF GUIDE CHANNEL SLOT.**

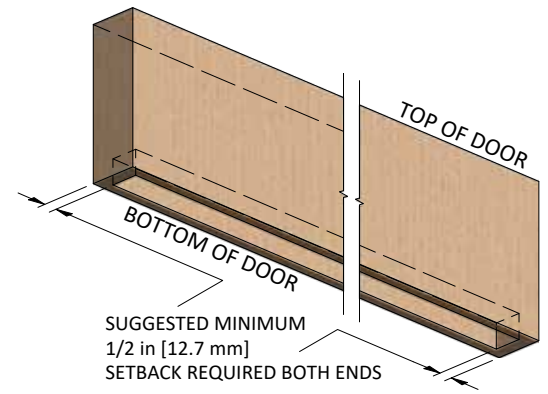

**STEP #6:**  
 PREPARE C-914 GUIDE CHANNEL SLOT IN BOTTOM OF DOOR:  
 1 in [25.4 mm] WIDE IN CENTER OF DOOR, 29/32 in [23 mm] DEEP AND SET BACK 1/2 in [12.7 mm] FROM BOTH EDGES OF DOOR. MAKE SLOT AS ACCURATE AS POSSIBLE FOR SECURE FIT AND NEAT APPEARANCE.

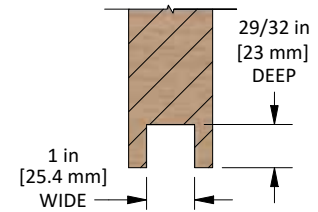

**STEP #7:**  
 CUT C-914 ALUMINUM GUIDE CHANNEL TO CORRECT LENGTH AS REQUIRED. DRILL HOLES IN C-914 GUIDE CHANNEL AND PRE-DRILL HOLES IN DOOR. LOCATE C-914 GUIDE CHANNEL IN SLOT AND SECURE CHANNEL INTO PLACE WITH (4) #8 X 3/4" PAN HEAD SCREWS [FT2].

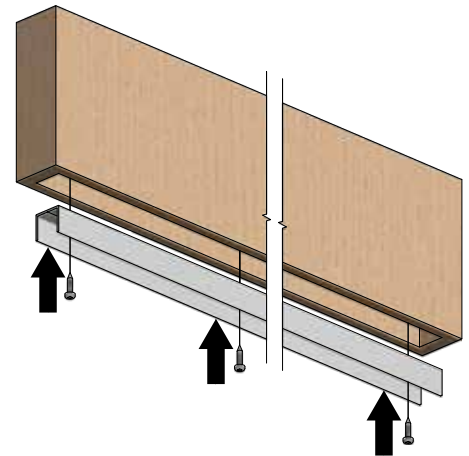

**STEP #8:**  
 POSITION C-913 GUIDE PER TYPICAL INSTALLATION LOCATION DETAILS (PAGE 2) AND SECURE TO FLOOR WITH (2) #10 X 1 1/2" FLATHEAD SCREWS [FT7].

FOR 120" KITS AND UP, C-913-2 DOUBLE ROLLER FLOOR GUIDE IS SUPPLIED. MINIMUM 4 in [101.6 mm] OVERLAP REQUIRED.

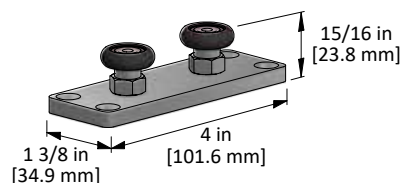
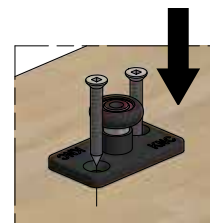

**STEP #9:**

RAISE DOOR, POSITION OVER GUIDE, AND UNDER HANGERS IN TRACK. LIFT DOOR UP AND ENGAGE TOP PLATE "U" SLOT WITH C-993 EASY CONNECT STUD. ADJUST DOOR HEIGHT AND PLUMB BY USING C-AR93 ADJUSTMENT ROD ON C-993 EASY CONNECT STUDS. LOCK FINAL HEIGHT ADJUSTMENT WITH K-LOCK NUTS USING 9/16" WRENCH.

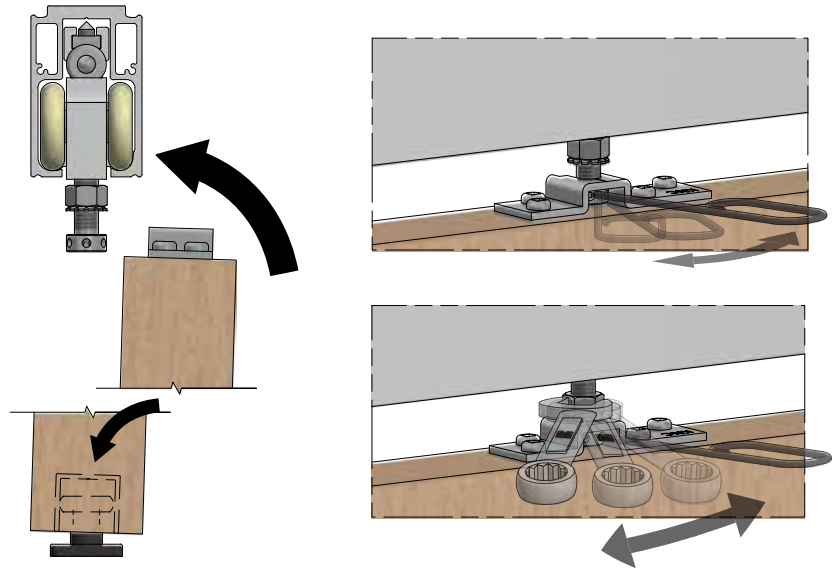

**STEP #10:**

AFTER DOOR HAS BEEN INSTALLED, POSITION DOOR APPROXIMATELY 5-10 in [127-254 mm] AWAY FROM FINAL POSITION AT ONE END (SHOWN BELOW WITH LEFT SIDE). PUSH LOOSE CC-101HD STOP (INSTALLED IN STEP #4) AGAINST HANGER BODY AS SHOWN BELOW.

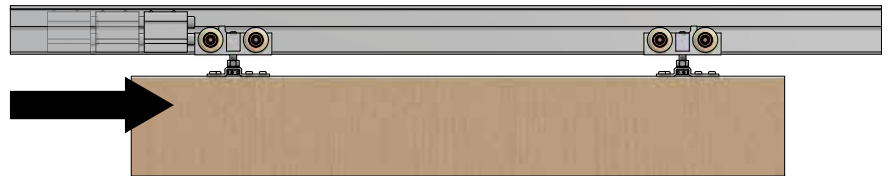

**STEP #11:**

WITH CC-101HD STOP LOOSE, SLIDE DOOR TO FINAL/DESIRED POSITION OF DOOR AS SHOWN BELOW.

**NOTE: ENSURE THAT STRIKE AND TRIM THICKNESS ARE TAKEN INTO CONSIDERATION FOR FINAL/DESIRED POSITION OF DOOR.**

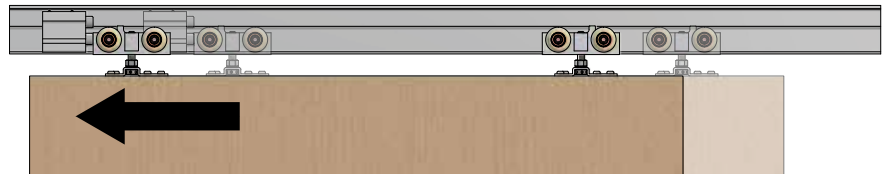

**STEP #12:**

ONCE FINAL POSITION IS ACHIEVED, SLIDE DOOR AWAY FROM CC-101HD STOP. LOCK CC-101HD STOP IN POSITION BY TIGHTENING TWO CAP SCREWS ON CC-101HD STOP WITH 3/16" ALLEN KEY (CC-101HD IS SECURED BY FRICTION FIT WITH CONE POINT SCREWS).



**STEP #13:**

REPEAT STEPS #10 - #12 FOR OPPOSITE SIDE.

**NOTE: ENSURE THAT STRIKE AND TRIM THICKNESS ARE TAKEN INTO CONSIDERATION FOR FINAL/DESIRED POSITION OF DOOR.**

**STEP #14:**

BEFORE INSTALLING CC-2 CATCH 'N' CLOSE CLOSING DEVICES, ENSURE DEVICES ARE IN RETRACTED POSITION AS SHOWN BELOW. IF NOT IN REQUIRED POSITION, SLIDE HOOK DOWN UNTIL IT LOCKS IN POSITION.

**NOTE: REQUIRES SIGNIFICANT FINGER PRESSURE.**

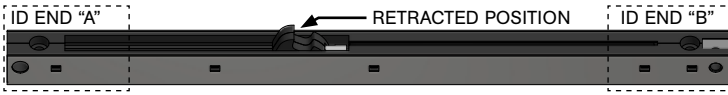

**IMPORTANT CATCH 'N' CLOSE CLOSING DEVICE NOTES:**

IF DOORS ARE 200LBS OR LESS, ENSURE CC-2 CATCH 'N' CLOSE CLOSING DEVICES ARE USED.

**STEP #15:**

PLACE CC-2 CATCH 'N' CLOSE CLOSING DEVICE INTO TRACK WITH LEADING END "A" RESTING AGAINST UPPER BODY ON CC-101HD STOPS INSTALLED PREVIOUSLY. SEE ILLUSTRATIONS BELOW:

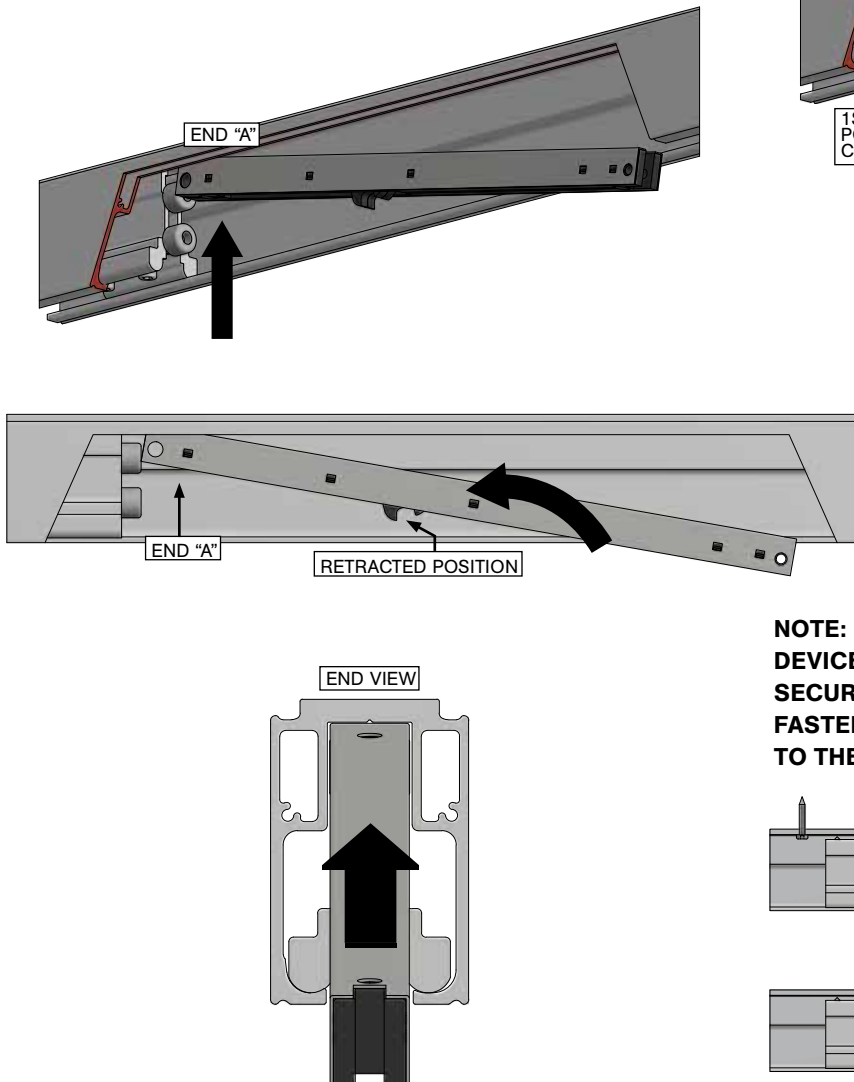

**STEP #16:**

SECURE CC-2 CATCH 'N' CLOSE CLOSING DEVICE TO TRACK WITH (2) #10 X 1 1/2" SELF DRILLING SCREWS [FT5]. REPEAT FOR OPPOSITE END WITH CC-2 CATCH 'N' CLOSE CLOSING DEVICE INSTALLED IN REVERSE AS SHOWN ON FRONT PAGE IN "COMPLETE INSTALLATION ELEVATION VIEW" ILLUSTRATION.

**NOTE: IF USING IMPACT DRIVE TO SECURE CC-2 CATCH 'N' CLOSE DEVICES, DO NOT OVERTIGHTEN SCREWS. IT IS RECOMMENDED TO PRE-DRILL TRACK WITH Ø9/64 in [3.6 mm] DRILL BIT. SECURE FIRST SCREW CLOSEST TO CC-101HD STOP ONLY AND TEST SYSTEM BY SLIDING DOOR TO ACTIVATE CC-2 CATCH 'N' CLOSE. IF IT IN CORRECT POSITION, SECURE WITH SECOND SCREW. REMOVE ANY DRILL FILLINGS FROM INSIDE TRACK.**

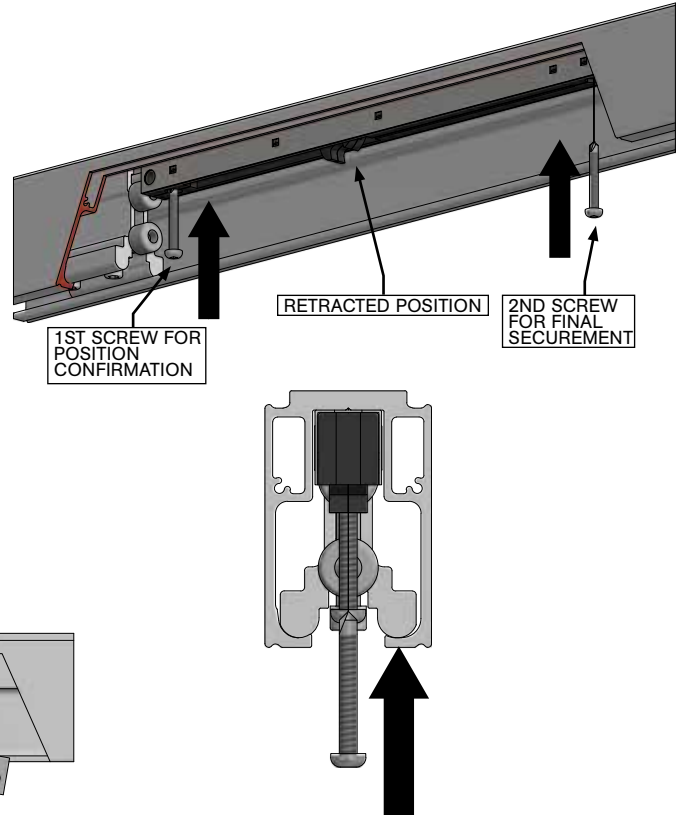

**NOTE: ENSURE AREA OF TRACK WHERE CATCH 'N' CLOSE DEVICE WILL BE INSTALLED IS FREE OF FASTENERS. SECURING CATCH 'N' CLOSE DEVICE ONTOP OF A FASTENER MAY LEAD TO OPERATION ISSUES OR DAMAGE TO THE SYSTEM.**

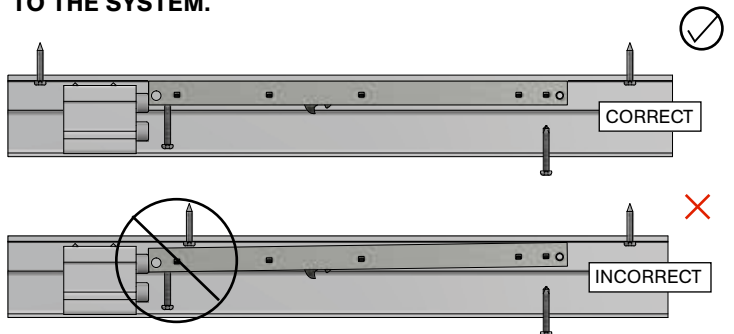

**STEP #17:**

TEST COMPLETE CATCH 'N' CLOSE SYSTEM BY SLIDING DOOR TO BOTH LEFT AND RIGHT TO ACTIVATE CLOSING DEVICES.



## CC-940 FASCIA & CC-941/CC-942/CC-943 END CAP INSTALLATION

### STEP #F1:

CUT CC-940 FASCIA TO CORRECT LENGTH IF REQUIRED. TYPICALLY, FASCIA IS SAME LENGTH AS TRACK PREVIOUSLY INSTALLED.

### STEP #F2:

LIFT FASCIA UP TO TRACK AND SNAP-ON AS SHOWN BELOW.

**NOTE: IF FASCIA IS LOOSE AND A TIGHTER FIT IS DESIRED, USE A RUBBER Mallet ON INSIDE LEG OF FASCIA TO REDUCE GAP (AT +/-24 in [610 mm] INTERVALS).**

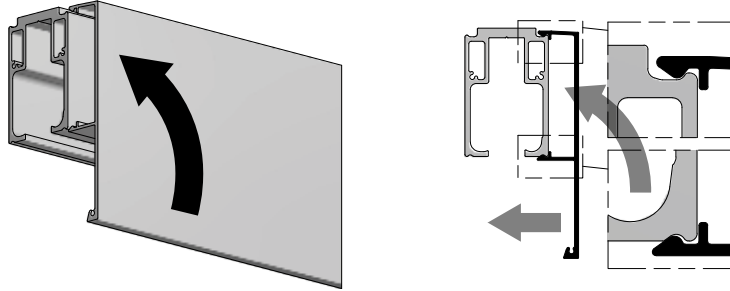

### STEP #F3:

INSTALL END CAP AS SHOWN BELOW WITH THE SUPPLIED #4 X 5/16" FLAT HEAD SCREWS [FT29] (2 - 4 SCREWS PER END CAP PROVIDED).

**NOTE: DO NOT INSTALL WITH IMPACT DRIVER.**

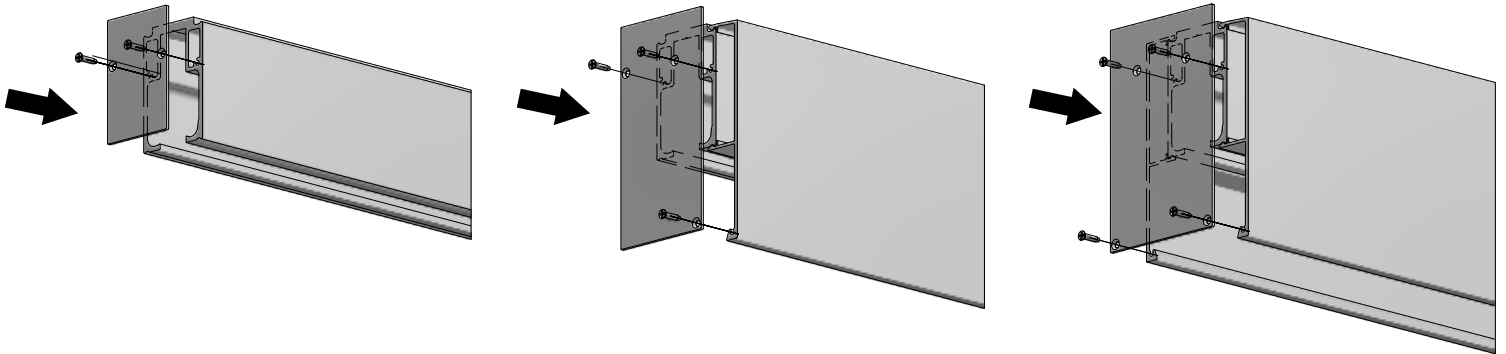

## TROUBLESHOOTING

ISSUE	SOLUTION
CHATTER/NOISE WHEN DOOR IS SLIDING	ENSURE THERE ARE NO ALUMINUM SHAVINGS WITHIN TRACK. SHAVINGS CAN BECOME EMBEDDED IN NYLON TIRES AND CAUSE NOISE DURING OPERATION.
DOOR IS HARD TO MOVE	ENSURE GUIDE CHANNEL SECURED TO BOTTOM OF DOOR IS NOT OVERTIGHTENED AS THIS COULD CAUSE SIDES OF GUIDE CHANNEL TO "PINCH" GUIDE. REMOVE DOOR AND CHECK GUIDE CHANNEL BY ROLLING GUIDE ROLLER IN CHANNEL TO ENSURE SMOOTH TRAVEL. THERE SHOULD BE LITTLE TO NO RESISTANCE.  ENSURE DOOR IS NOT DRAGGING ON BOTTOM OF FLOOR/GUIDES AND ADJUST HEIGHT OF DOOR AS REQUIRED.
DOOR RATTLES	ENSURE LOCKING NUTS & SCREWS ON HANGERS ARE SECURED AND NOT LOOSE.
DOOR IS NOT ENGAGING CLOSING DEVICE	ENSURE HANGERS ARE CORRECTLY ORIENTED. SEE STEPS #4 - #5.  ENSURE CC-2 CATCH 'N' CLOSE CLOSING DEVICES ARE IN CORRECT RETRACTED OR EXTENDED POSITION PRIOR TO SLIDING DOOR CLOSED/OPEN. SEE STEP #15.
REPLACING THE CC-2 CATCH 'N' CLOSE DEVICE	THE CATCH 'N' CLOSE TRACK AND HARDWARE SYSTEM HAS BEEN DESIGNED FOR EASY INSTALLATION. REMOVE TWO SCREWS THAT HOLD CC-2 CATCH 'N' CLOSE CLOSING DEVICE IN PLACE AND REPLACE DEVICE WITH A NEW ONE IF FAILURE OCCURS.

# TOP PLATE LOCATION TEMPLATE

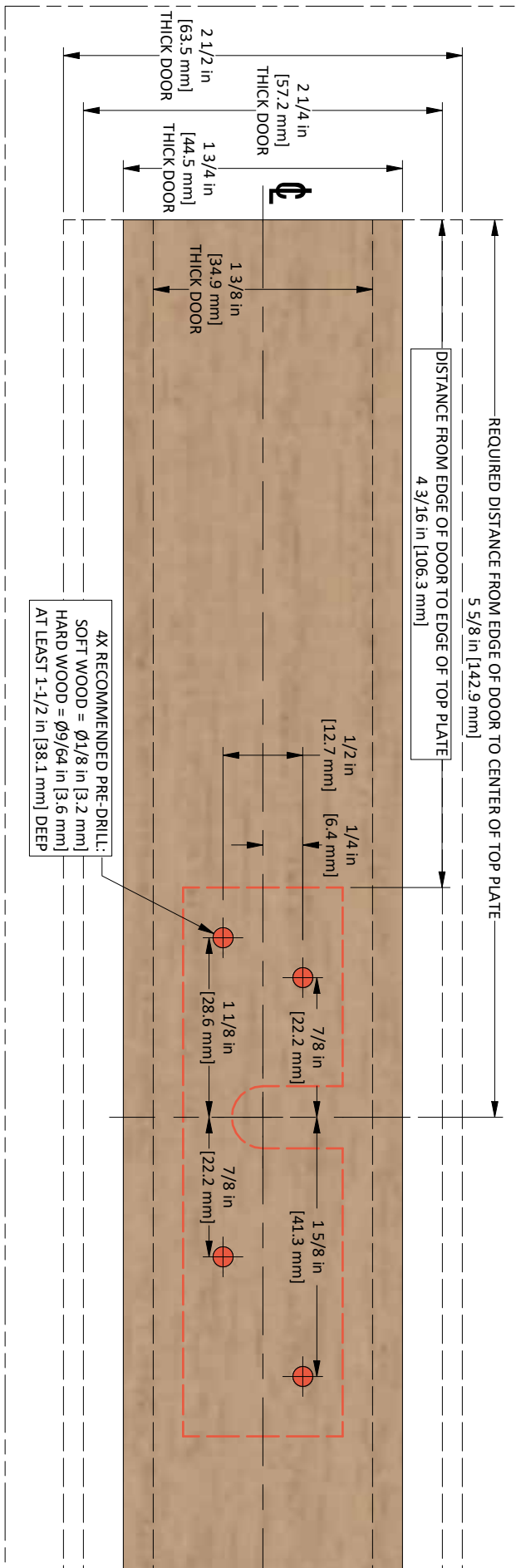

# TOP PLATE LOCATION TEMPLATE

