

CCS- and CCSF-993

Installation Instructions

Easy Connect Catch 'N' Close System

- Prevents bouncing and slamming of sliding doors
- Can be installed on both opening and closing ends of doors as narrow as 18 in [457 mm]
- Cycle tested up to 150,000 times
- For up to 200 lbs. [90 kg] using CC-993 with CC-2

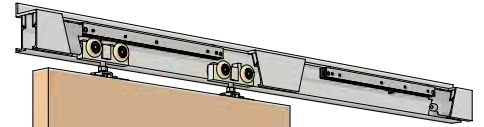

Parts List

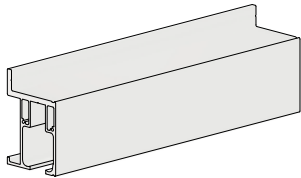

CC-908 Side Mount Track x length (1)

Length = 2x door width, example:

36 in [914 mm] door = 72 in [1829 mm] track

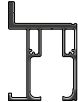

CC-938 Hanger Body (2)
c/w wheels



C-AR93 Adjustment Rod (1)



3/8-16 K-Lock Nut (2)
[FT21]



C-993 Easy Connect Stud (2)



C-993 Top Plate (2)



#10 x 1-1/4" Pan Head Screws (8)
[FT4]



CC-2 Catch 'N' Close Device (2)
See details in instruction steps



#10 x 1-1/2" Self-Drilling Screws (4)
[FT5]

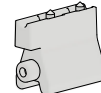

CC-101HD Catch 'N' Close In-Track Stops (2)

Complete CCS-993 kit illustrated. Cut-outs in track to expose components.

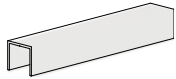

C-914 Guide Channel x length (1)

Length = door width, example:

36 in [914 mm] door = 36 in [914 mm] guide channel less set-backs if desired



#8 x 3/4" Pan Head Screws (4)
[FT2]

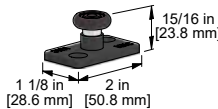

C-913 Floor Guide (1)



#10 x 1-1/2" Flat Head Screws (2)
[FT7]

Optional Add-on Products

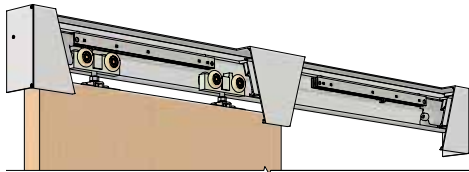

Complete CCSF-993 kit illustrated. Cut-outs in track and fascia to expose components.

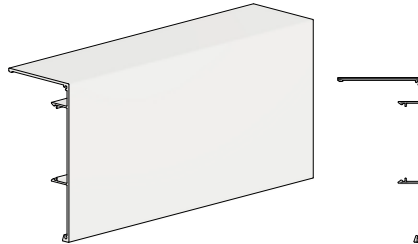

CC-980 Snap-on Fascia x length (1)
Length = same as track length, example:
72 in [1829 mm] track = 72 in [1829 mm] fascia

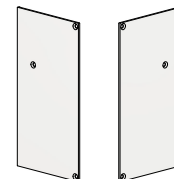

CC-982 End Caps (2)
Left and right



#4 x 5/16" Flat Head Screws (6)
[FT29]

Production Details and Dimensions

Elevation View

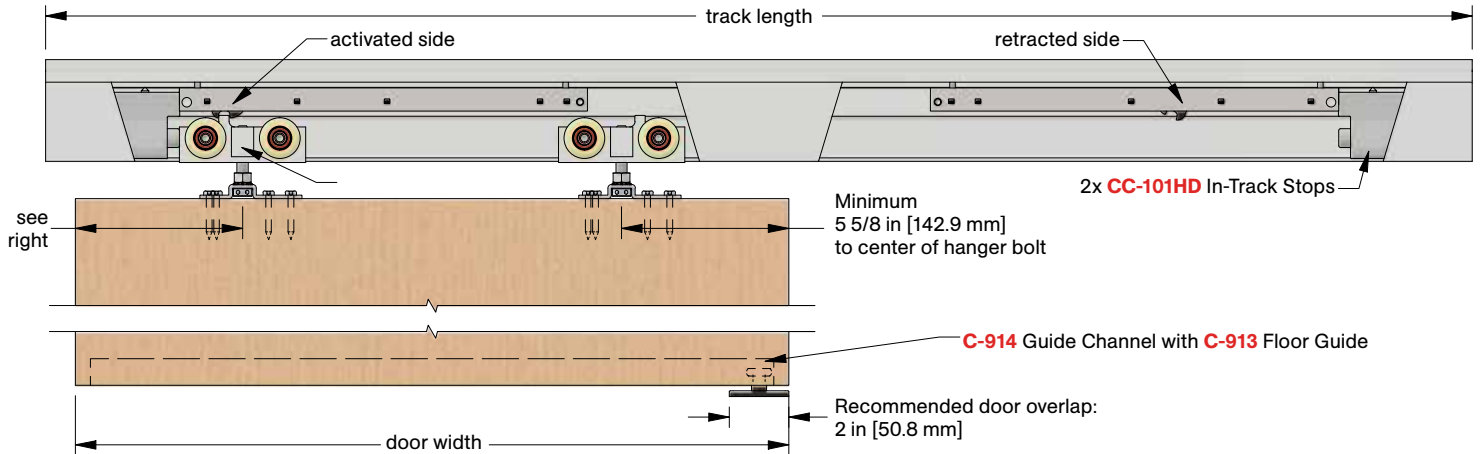

Section View

* indicates mounting flange on CC-908 track

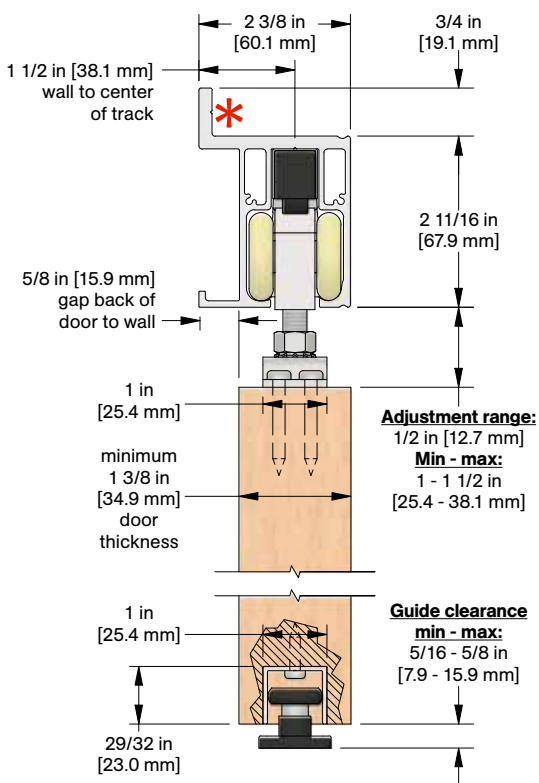

Optional CC-980 Snap-on Fascia, illustrated as solid black profile

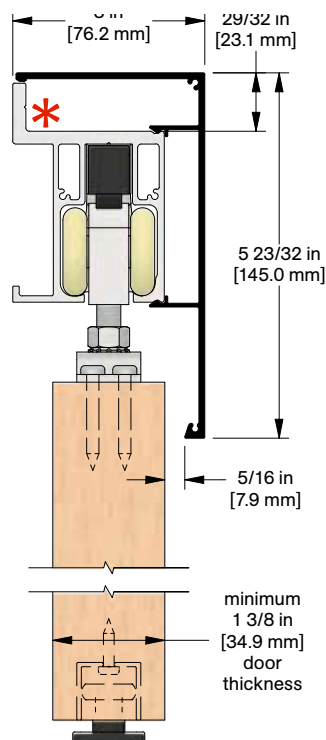

Typical installation location for floor guides

For barn door applications

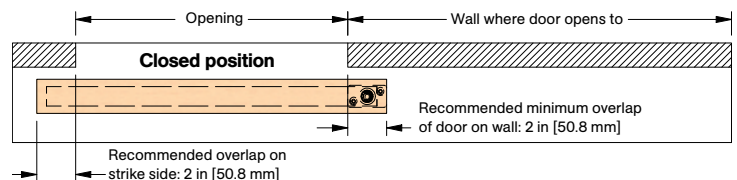
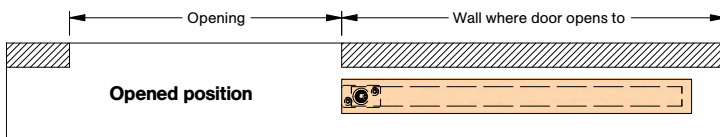

Installation Steps

Step #1:

Determine door size, header height, track position, and bottom clearance based on kit code ordered by using dimensions shown in detail views on previous page.

Step #2:

Note: If access to the ends of track is not available, steps #3 and 4 must be completed before step #2.

Cut CC-908 aluminum track to size if required, typically 2x door width. Locate and pre-drill holes in mounting flange on track. Secure track to structural support/backing.

Note: Solid backing is required. Recommended to use 5/16 in [7.9 mm] diameter lag or structural bolts to secure track. Spacing is recommended to be between 12-16 in [304-406 mm] on center. Consult structural engineer to ensure adequate support and fastening.

Holes are not pre-drilled and must be marked and drilled by installer.

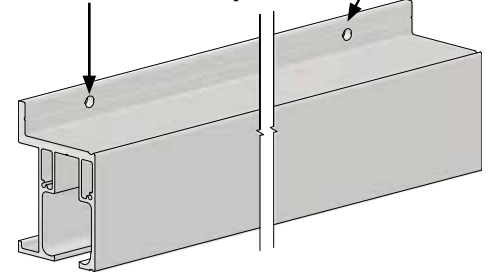

Step #3:

Assemble CC-993 Catch 'N' Close Hangers as shown below:

Fig. 1 Thread 3/8-16 K-Lock Nut [FT21] onto C-993 Easy Connect Stud with lock washer facing bolt head.

Fig. 2 Thread assembly from **Fig. 1** into CC-938 Hanger Body from underside, side opposite the trigger, do not thread in fully.

Fig. 3 Completed CC-993 Hanger assembly, 2 x required.

Fig. 1

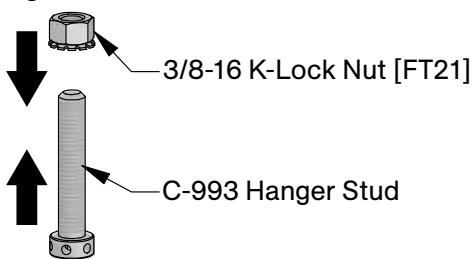

Fig. 2

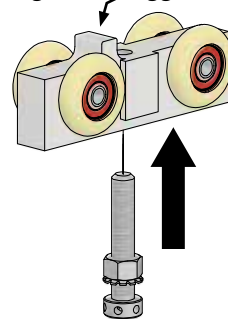
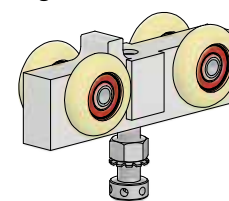

Fig. 3



Step #4:

Slide one (1) CC-993 Hanger assembly (*) with trigger facing end of track and one (1) CC-101HD In-Track Stop (●) into each end of track, as shown below.

Note: Leave screws on CC-101HD In-Track Stops (●) loose to allow stops to slide freely within track. Rubber bumpers of each stop (●) should face inward, toward middle of track.

- * CC-993 Hanger
- CC-101HD In-Track Stops

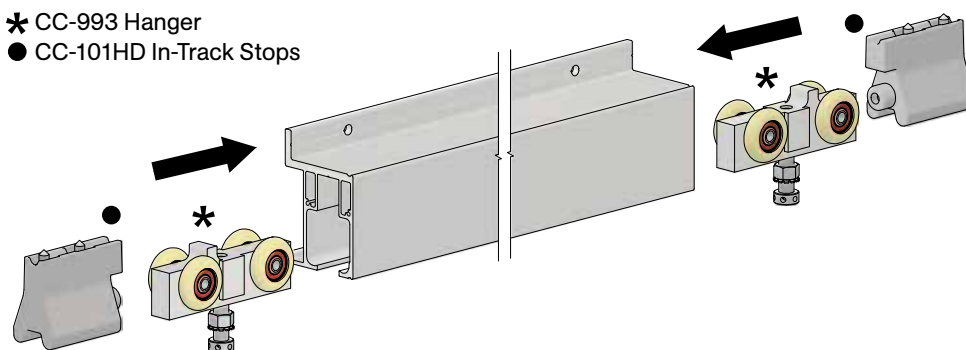
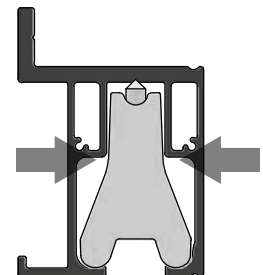
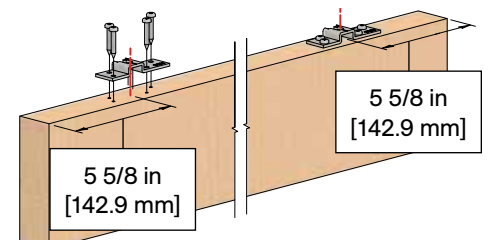

Illustration below shows correct positioning of stops in track



Step #5:

Locate center of 'U' slot (dash line shown right) of C-993 Top Plate at 5 5/8 in [142.9 mm] from each edge of door or see template for dimensions from edge of door to leading edge of top plates. Mark screw hole locations or use template on page 8 and pre-drill Ø1/8 in [3.2 mm] holes at least 1 1/2 in [38.1 mm] deep. Secure C-993 Top Plates with (4 per hanger) #10 x 1-1/4" Pan Head Screws [FT4]. See right.



Note: If door has sufficient overlap, guide channel can be recessed into door without cutting a full-length slot in door. If guide channel will be fully recessed, it is recommended to have at least 1/2 in [12.7 mm] door material at each end of door before start of guide channel slot.

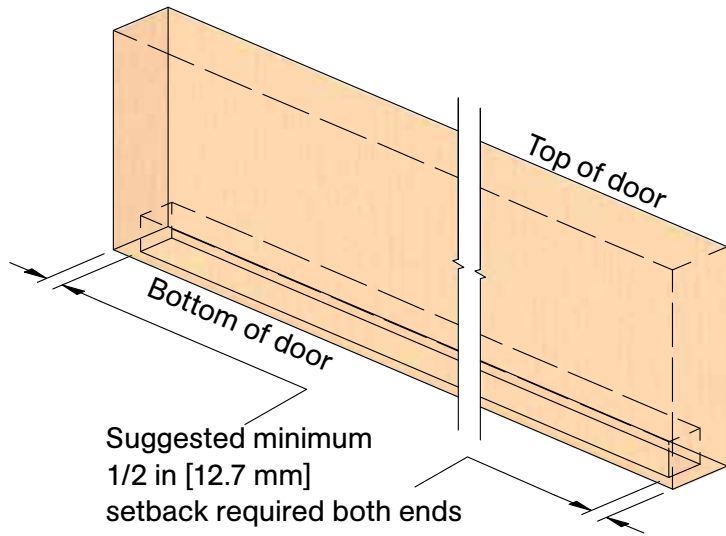

Step #6:

Prepare C-914 Guide Channel slot in bottom of door: 1 in [25.4 mm] wide in center of door, 29/32 in [23 mm] deep and set back 1/2 in [12.7 mm] from both edges of door. Make slot as accurate as possible for secure fit and neat appearance.

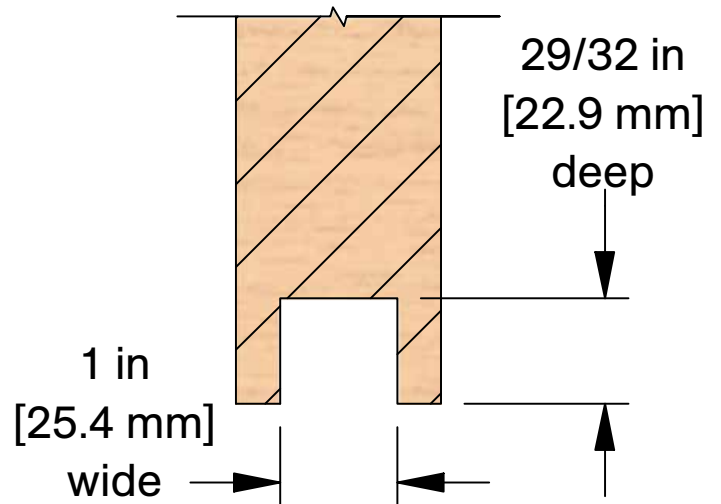

Step #7:

Cut C-914 aluminum guide channel to correct length as required. Drill holes in C-914 Guide Channel and pre-drill holes in door. Locate C-914 Guide Channel in slot and secure channel in place with (4) #8 x 3/4" Pan Head Screws [FT2].

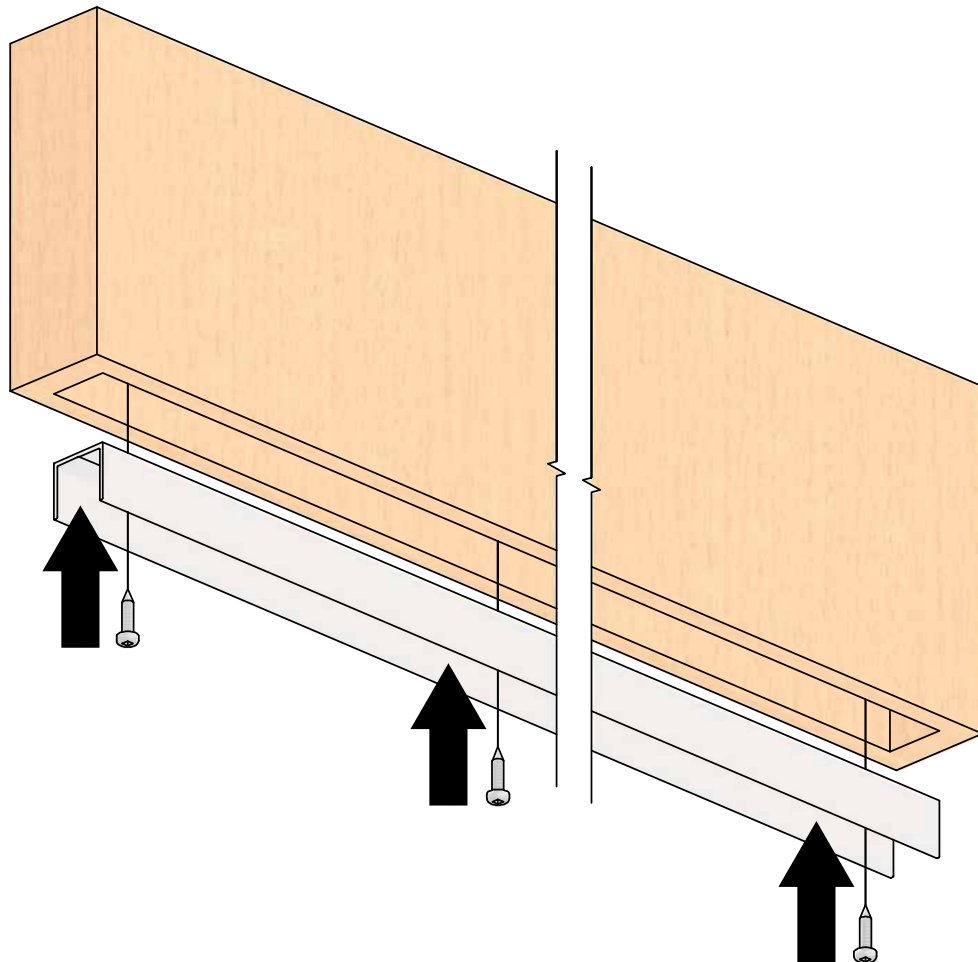

Step #8:

Position C-913 Guide per typical installation location details, page 2, and secure to floor with (2) #10 x 1-1/2" Flat Head Screws [FT7].

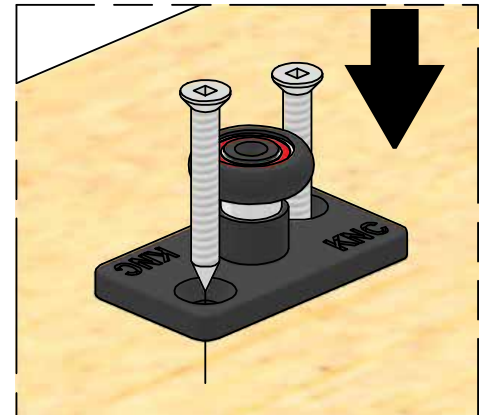

For 120 in [3048 mm] kits and up, C-913-2 Double Roller Floor Guide is supplied. Minimum 4 in [101.6 mm] overlap required.

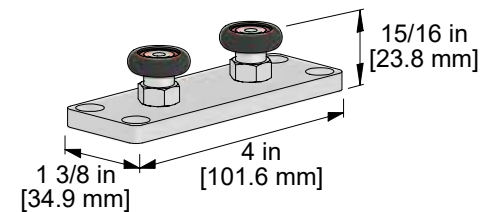

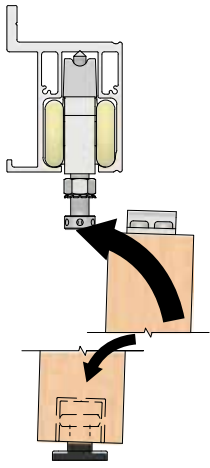

Step #9:

Raise door, position over guide, and under hangers in track. Lift door up and engage top plate 'U' slot with C-993 Easy Connect Stud. Adjust door height and plumb by using C-AR93 Adjustment Rod on C-993 Easy Connect Studs. Lock final height adjustment with k-lock nuts using 9/16 in wrench.

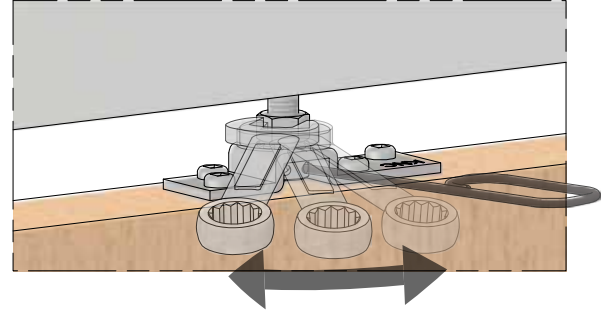
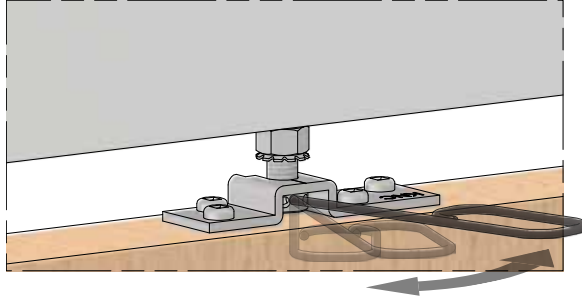

Step #10:

After door has been installed, position door approximately 5-10 in [127-254 mm] away from final position at one end, shown below with left side. Push loose CC-101HD Stop, installed in **step #4**, against hanger body.



Step #11:

With CC-101HD Stop loose, slide door to final/desired position.

Note: Ensure that door protrusion and any finishing trim thicknesses are taken into consideration for final/desired position of door.



Step #12:

Once final position is achieved, slide door away from CC-101HD Stop. Lock CC-101HD Stop in position by tightening two (2) cap screws on CC-101HD Stop with 3/16 in [4.8 mm] Allen Key. CC-101HD is secured by friction fit with cone point screws.



Step #13:

Repeat **steps #10 - 12** for opposite side.

Note: Ensure that door protrusion and any finishing trim thicknesses are taken into consideration for final/desired position of door.

Step #14:

Before installing CC-2 Catch 'N' Close Devices, ensure they are in the retracted position as shown below. If they are not in the correct position, slide the hook downward until it locks into place.

Note: Requires significant finger pressure.

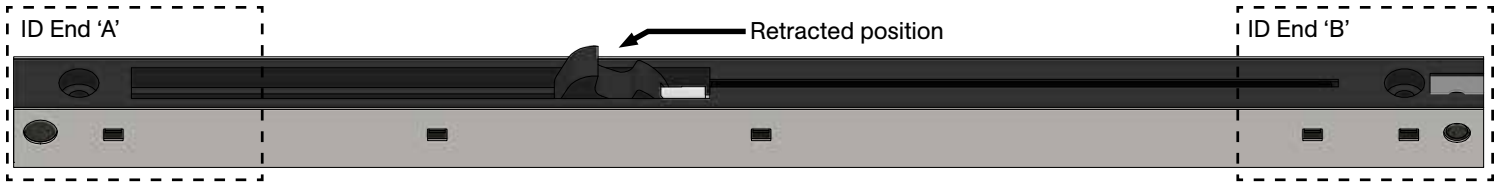

Important Catch 'N' Close Device Notes:

If doors are 200 lbs. [90 kg] or less, ensure CC-2 Catch 'N' Close Devices are used.

Step #15:

Place CC-2 Catch 'N' Close Device into track with leading end 'A' resting against upper body on CC-101HD Stops installed previously. See illustrations below:

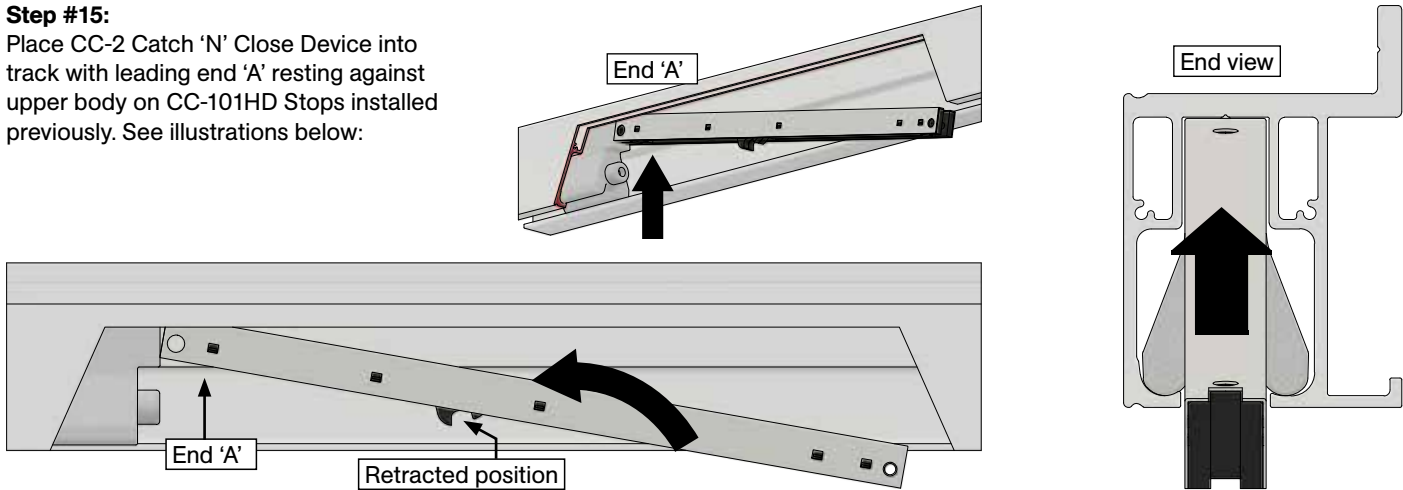

Step #16:

Secure CC-2 Catch 'N' Close Device to track with (2) #10 x 1-1/2" Self-Drilling Screws [FT5]. Repeat for opposite end with CC-2 Catch 'N' Close Device installed in reverse as shown on front page in "Elevation View" illustration.

Note: If using impact driver to secure CC-2 Catch 'N' Close Devices, do not overtighten screws. It is recommended to pre-drill track with Ø9/64 in [3.6 mm] drill bit. Secure first screw closest to CC-101HD Stop only and test system by sliding door to activate CC-2 Catch 'N' Close. If in correct position, secure with second screw. Remove any drill fillings from inside track.

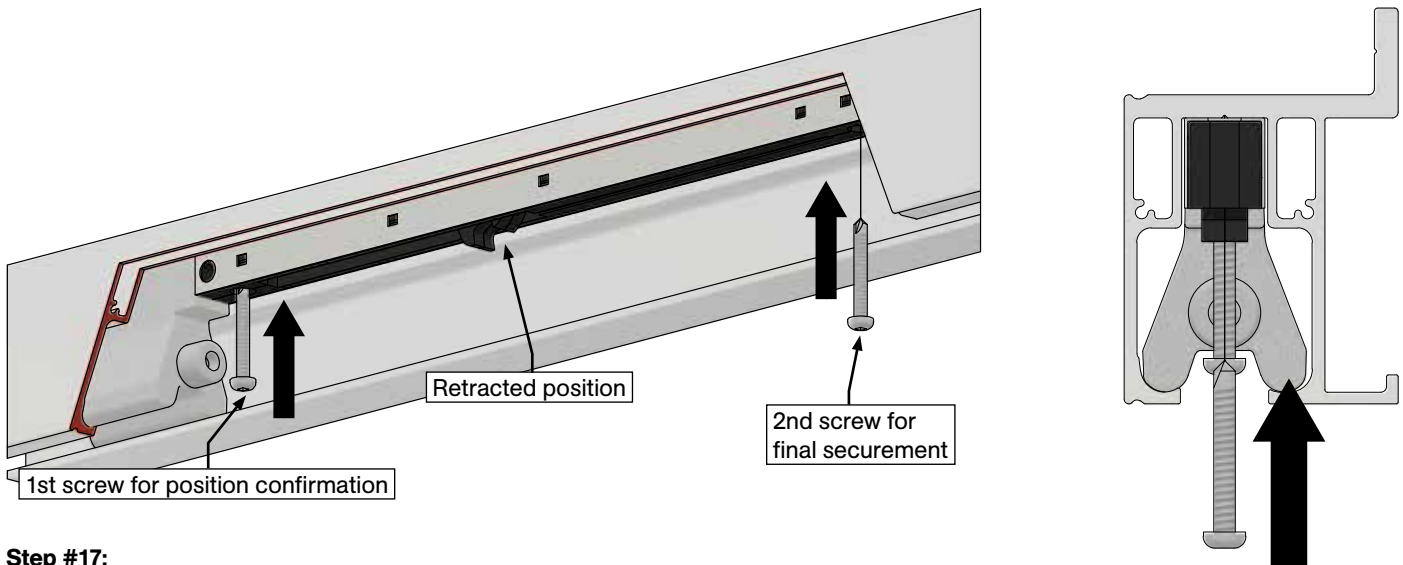

Step #17:

Test complete Catch 'N' Close system by sliding door to both left and right to activate closing devices.

Optional CC-980 Fascia and CC-982 End Cap Installation

Step #F1:

Cut CC-980 Fascia to match track length.

Step #F2:

Lift fascia up to track and snap on as shown right.

Note: If fascia is loose, use a rubber mallet on inside leg at 24 in [610 mm] intervals to tighten fit.

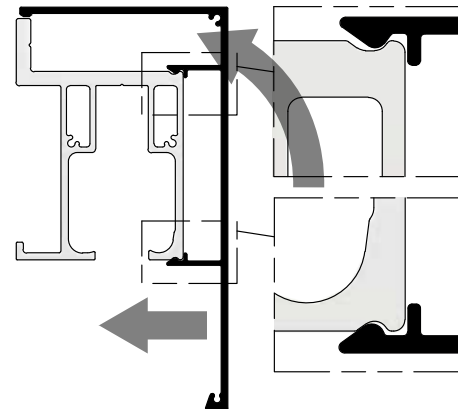
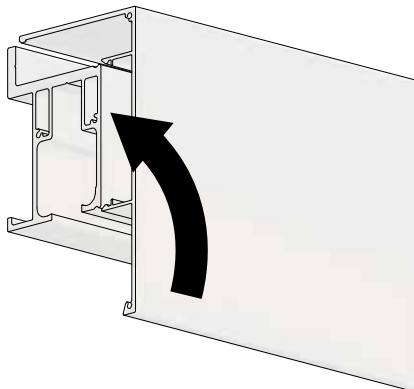

Step #F3:

Install CC-982 End Cap as shown right with the supplied #4 x 5/16" Flat Head Screws [FT29], 3 screws per end cap provided.

Note: Do not install with impact driver.

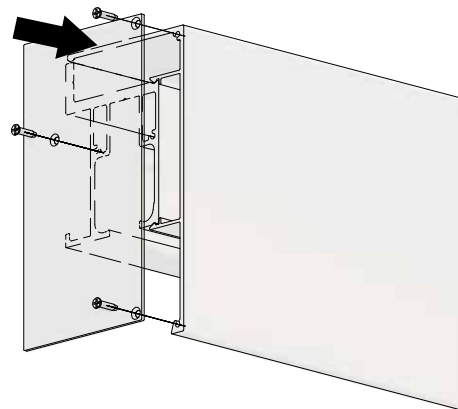

Troubleshooting

Issue	Solution
Chatter/noise when door is sliding	Ensure there are no aluminum shavings within track. Shavings can become embedded in nylon tires and cause noise during operation.
Door is hard to move	Ensure guide channel secured to bottom of door is not over-tightened as this could cause sides of guide channel to pinch guide. Remove door and check guide channel by rolling guide roller in channel to ensure smooth travel. There should be little to no resistance. Ensure door is not dragging on bottom of floor/guides and adjust height of door as required.
Door rattles	Ensure locking nuts and screws on hangers are secured and not loose.
Door is not engaging closing device	Ensure hangers are correctly oriented. See steps #4 - 5 . Ensure CC-2 Catch 'N' Close Devices are in correct retracted or extended position prior to sliding door closed/open. See step #14 .
Replacing the CC-2 Catch 'N' Close Device	The Catch 'N' Close track and hardware system is designed for easy installation. If a closing device fails, remove the two screws holding it in place and replace the device with a new one.

Top Plate Location Template

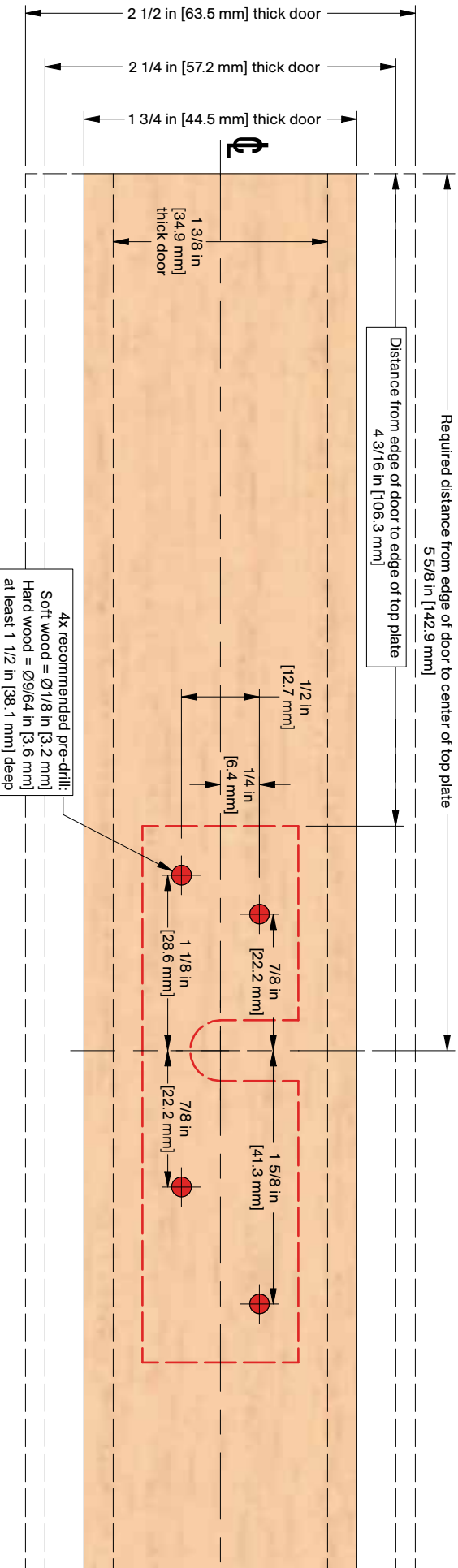

Top Plate Location Template

