

CCSSF-810

Installation Instructions

Zero Clearance Catch 'N' Close System

- Prevents bouncing and slamming of sliding doors
- Can be installed on both opening and closing ends of doors as narrow as 30 in [762 mm]
- Cycle tested up to 150,000 times
- For up to 300 lbs. [136 kg] using CC-810 with CC-3

Parts List

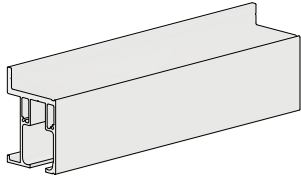

CC-908 Side Mount Track x length (1)

Length = 2x door width, example:

36 in [914 mm] door = 72 in [1829 mm] track



C-819 5/32" Allen Key (1)

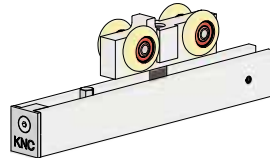

CC-810 Zero Clearance Catch 'N' Close Hanger (2)
Complete assembly

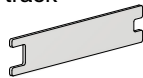

C-818 Adjustment Wrench (1)

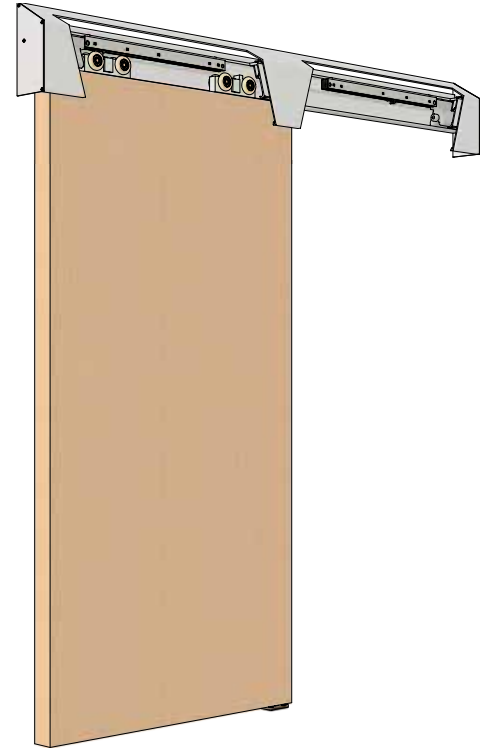

Complete CCSSF-810 kit illustrated.
Cut-outs in track to expose components.

Disassembled Parts List

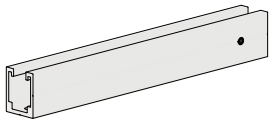

C-811 'U'-Housing (1)



CC-912 Hanger Body (1)
c/w wheels



C-815 End Cap (1)

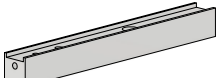

C-812 'H'-Bar (1)



C-814 Hanger Stud (1)



C-816 Safety Lock Bolt (1)



1/4-20 x 1-1/4" Flat Head Socket Cap Screw (1)
[FT41]



#10 x 1-3/4" Flat Head Screws (10)
[FT9]

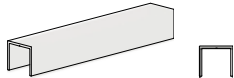

C-914 Guide Channel x length (1)

Length = door width, example:

36 in [914 mm] door = 36 in [914 mm] guide channel less set-backs if desired

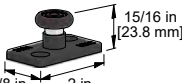

C-913 Floor Guide (1)



Catch 'N' Close Device (2)
See details in instruction steps



CC-101HD Catch 'N' Close In-Track Stops (2)



#8 x 3/4" Pan Head Screws (4)
[FT2]



#10 x 1-1/2" Flat Head Screws (2)
[FT7]



#10 x 1-1/2" Self-Drilling Screws (4)
[FT5]

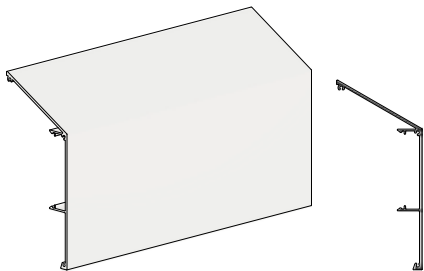

CC-990 Snap-on Fascia x length (1)

Length = same as track length, example:

72 in [1829 mm] track = 72 in [1829 mm] fascia

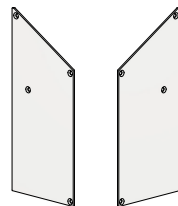

CC-991 End Caps (2)
Left and right



#4 x 5/16" Flat Head Screws (8)
[FT29]

Product Details and Dimensions

Elevation View

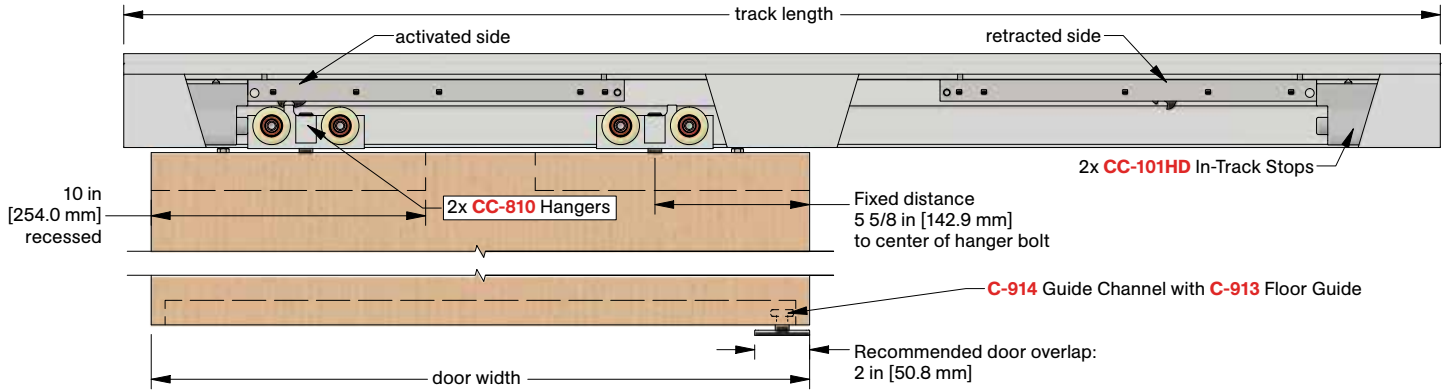

Section View

* Indicates mounting flange on CC-908 Track

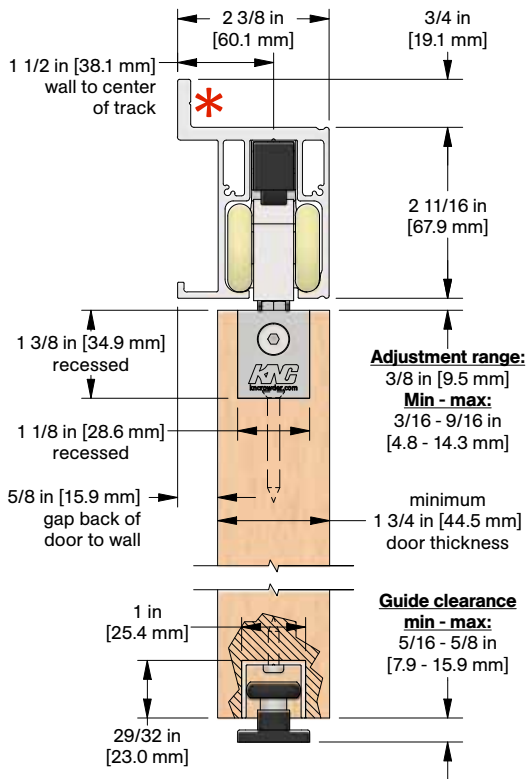

CC-990 Snap-on Fascia, illustrated as solid black profile

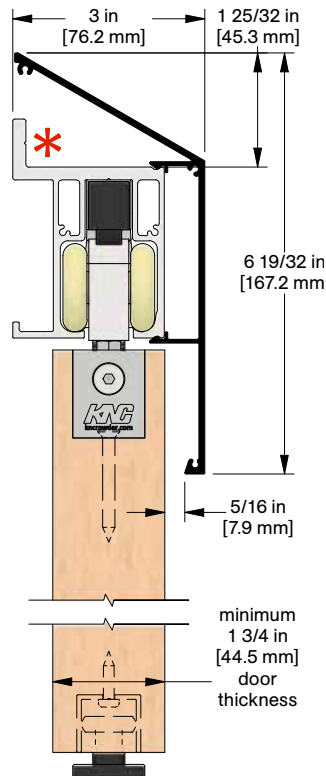

Typical installation location for floor guides

For barn door applications

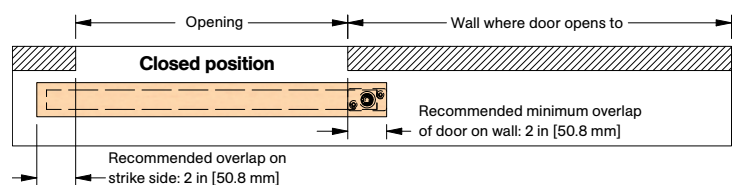
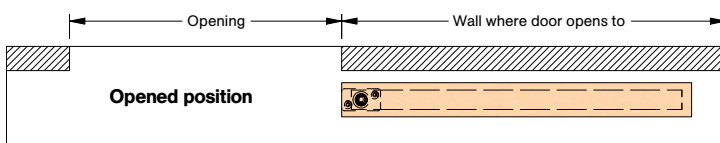

Installation Steps

Step #1:

Determine door size, header height, track position, and bottom clearance based on kit code ordered by using dimensions shown in detail views on previous page.

Step #2:

Note: If access to ends of track is not available, steps #3 and 4 must be completed before step #2.

Cut CC-908 aluminum track to size if required, typically 2 x door width. Locate and pre-drill holes in mounting flange on track. Secure track to structural support/backing.

Note: Solid backing is required. Recommended to use 5/16 in [7.9 mm] diameter lag or structural bolts to secure track. Spacing is recommended to be between 12-16 in [304-406 mm] on center. Consult structural engineer to ensure adequate support and fastening.

Holes are not pre-drilled and must be marked and drilled by installer.

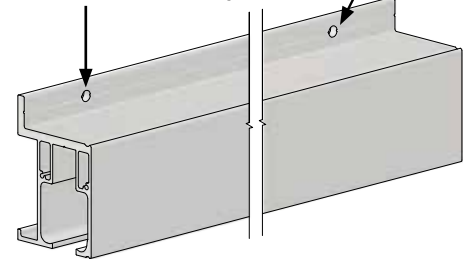

Step #3:

Disassemble CC-810 Catch 'N' Close Hangers as shown below:

Fig. 1 Remove 1/4-20 x 1-1/4" Flat Head Socket Cap Screw [FT41] with supplied C-819 5/32" Allen Key, lift out C-815 End Cap and loosen C-816 Safety Lock Bolt with supplied C-818 Adjustment Wrench.

Fig. 2 Slide the hanger assembly out of the C-811 'U'-Housing

Fig. 3 Complete disassembled hanger assembly, 2 x required

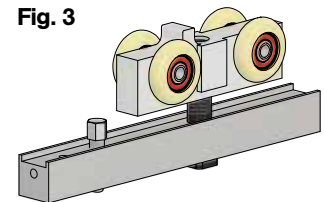
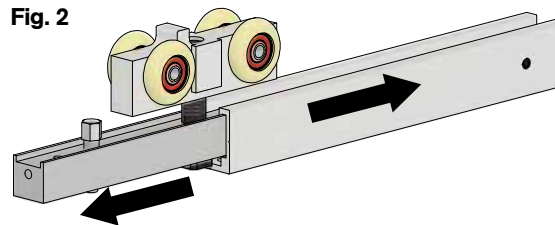
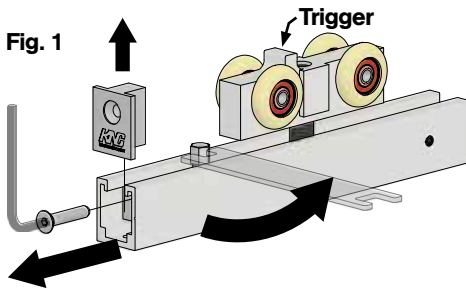

Step #4:

Slide one (1) CC-810 Hanger assembly (★) with trigger facing end of track and one (1) CC-101HD In-Track Stop (●) into each end of track, as shown below.

Note: Leave screws on CC-101HD In-Track Stops (●) loose to allow stops to slide freely within track. Rubber bumpers of each stop (●) should face inward, toward middle of track.

- ★ CC-810 Hanger
- CC-101HD In-Track Stops

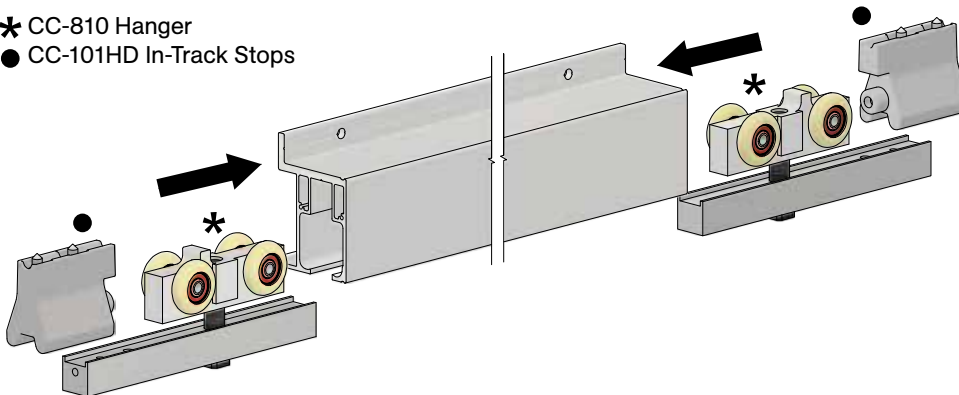
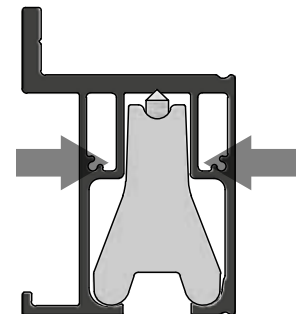
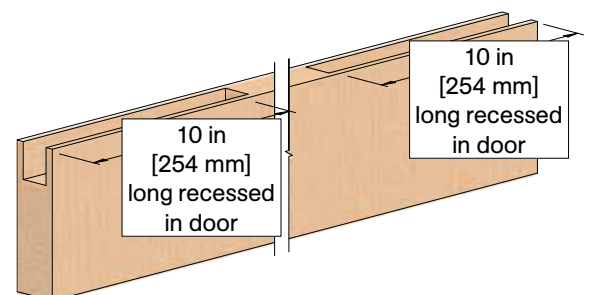
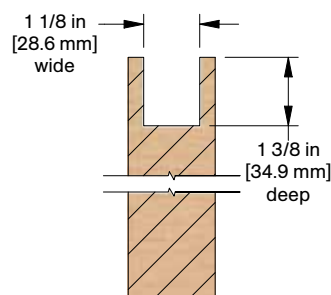

Illustration below shows correct positioning of stops in track



Step #5:

Prepare door to receive C-811 'U'-Housing flush with top edge of door. Slots must be 1 1/8 in [28.6 mm] wide, 1 3/8 in [34.9 mm] deep, and 10 in [254 mm] long. See right.



Note: If door has sufficient overlap, guide channel can be recessed into door without cutting a full-length slot in door. If guide channel will be fully recessed, it is recommended to have at least 1/2 in [12.7 mm] door material at each end of door before start of guide channel slot.

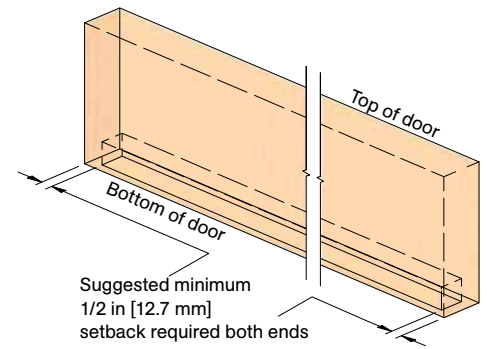

Step #6:

Prepare C-914 Guide Channel slot in bottom of door:
 1 in [25.4 mm] wide in center of door,
 29/32 in [23 mm] deep and set back
 1/2 in [12.7 mm] from both edges of door.
 Make slot as accurate as possible for
 secure fit and neat appearance.

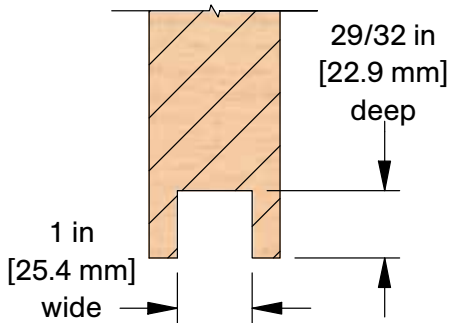

Step #7:

Place C-811 'U'-Housing into slot created in **step #5** with pin towards center of door in order to accommodate C-815 End Cap, see illustration right for details. Secure to door with five (5) #10 x 1-3/4" Flat Head Screws [FT9]. Repeat for opposite end of door.

1/8 in [3.2 mm] setback required for C-815 End Cap (same on opposite end)

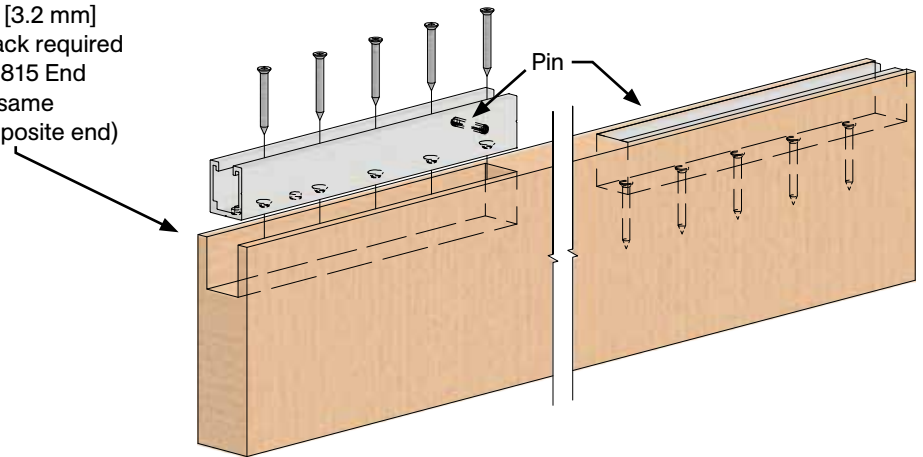

Step #8:

Cut C-914 aluminum guide channel to correct length as required. Drill holes in C-914 Guide Channel and pre-drill holes in door. Locate C-914 Guide Channel in slot and secure channel into place with four (4) #8 x 3/4" Pan Head Screws [FT2].

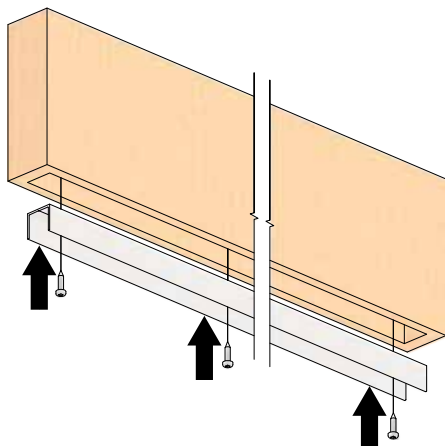

Step #9:

Position C-913 Guide per typical installation location details, page 2, and secure to floor with two (2) #10 x 1-1/2" Flat Head Screws [FT7].

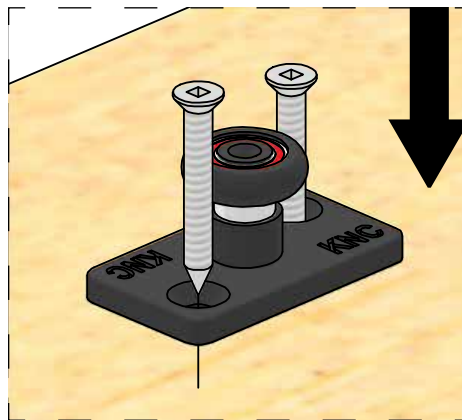

For 120 in [3048 mm] kits and up, C-913-2 Double Roller Floor Guide is supplied. Minimum 4 in [101.6 mm] overlap required.

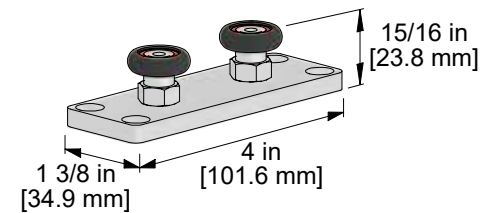

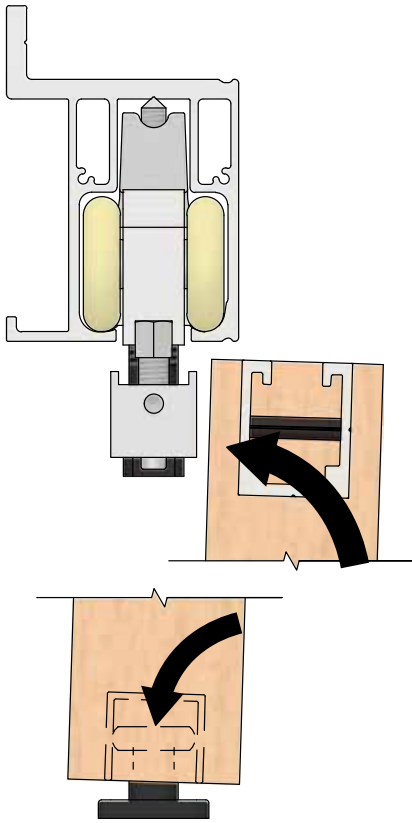

Step #10:

Raise door, position over guide. Slide the C-812 'H'-Bar into the C-811 'U'-Housings previously installed on doors.

Note: Threaded end hole must face outward. The square base of the C-814 Hanger Stud must be aligned with the lower channel slot of the C-811 'U'-Housing. The purpose of the square base is to prevent rotation of the bolt therefore securing the height adjustment. Repeat step for opposite end of door.

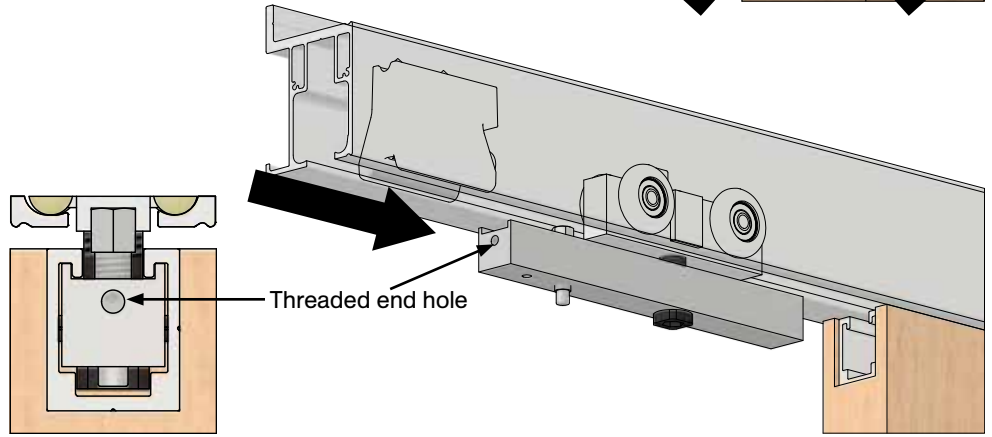
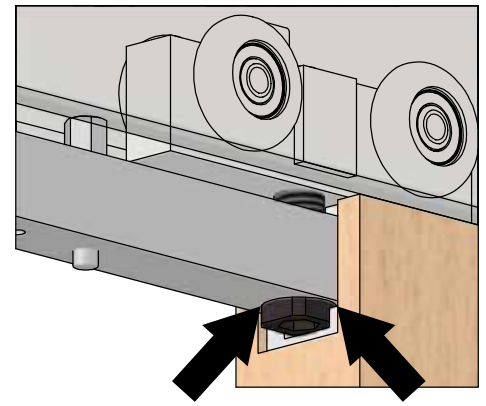

Step #11:

To adjust door height and plumb, slide C-812 'H'-Bar out of C-811 'U'-Housing and adjust C-814 Hanger Stud with C-818 Adjustment Wrench. Repeat until required height and plumb is achieved.

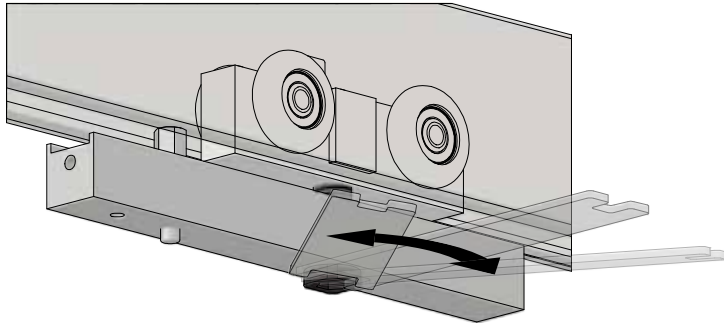

Hanger Adjustment View

Step #12:

Once adjustments have been finalized, secure C-816 Safety Lock Bolt with C-818 Adjustment Wrench.

Note: this custom bolt has been manufactured to engage a pre-drilled position in the C-811 'U'-Housing in order to prevent accidental disengagement.

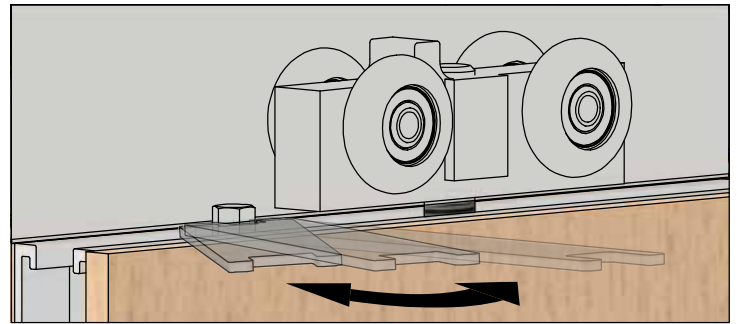

Step #13:

Install C-815 End Caps with the lower pin engaging the hole in the bottom of the C-811 'U'-Housing. Secure end cap with 1/4-20 x 1-1/4" Flat Head Socket Cap Screw [FT41] by using C-819 5/32" Allen Key.

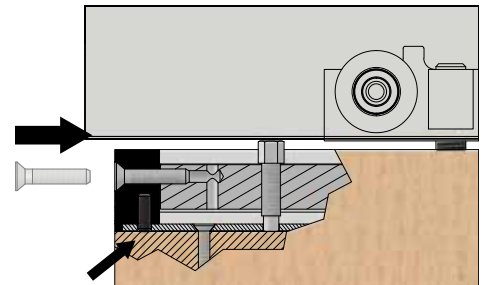
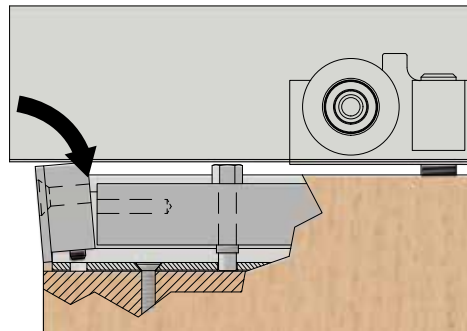
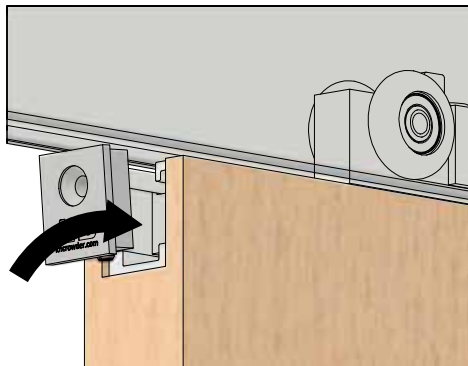

End cap pin must engage with C-811 'U'-Housing

Step #14:

After door has been installed, position door approximately 5-10 in [127-254 mm] away from final position at one end, shown below on left side. Push loose CC-101HD Stop, installed in **step #4**, against hanger body.



Step #15:

With CC-101HD Stop loose, slide door to final/desired position as shown below.

Note: Ensure that door protrusion and any finishing trim thicknesses are taken into consideration for final/desired position of door.

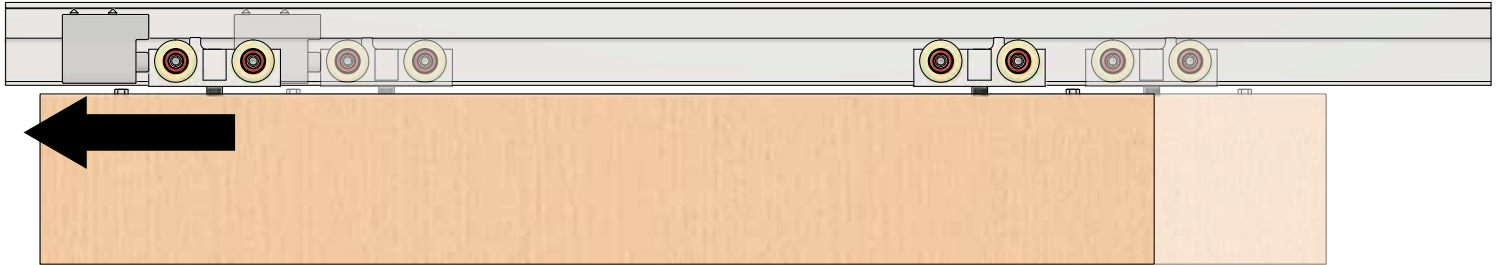

Step #16:

Once final position is achieved, slide door away from CC-101HD Stop. Lock CC-101HD Stop in position by tightening two (2) cap screws on CC-101HD Stop with 3/16 in [4.8mm] Allen Key. CC-101HD is secured by friction fit with cone point screws.



Step #17:

Repeat **steps #14 - 16** for opposite side.

Note: Ensure that door protrusion and any finishing trim thicknesses are taken into consideration for final/desired position of door.

Step #18:

Before installing Catch 'N' Close Devices, ensure they are in the retracted position as shown below. If they are not in the correct position, slide the hook downward until it locks into place.

Note: Requires significant finger pressure.

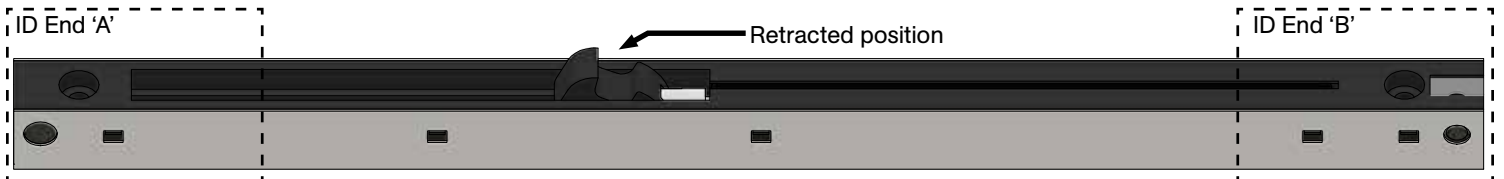

Important Catch 'N' Close Device Notes:

If doors are 200 lbs. [90 kg] or less, ensure CC-2 Catch 'N' Close Devices are used.

If doors are minimum 200 lbs. [90 kg] up to 300 lbs. [136 kg], ensure CC-3 Catch 'N' Close Devices are used.

Step #19:

Place Catch 'N' Close Device into track with leading end 'A' resting against upper body on CC-101HD Stops installed previously. See Illustrations below:

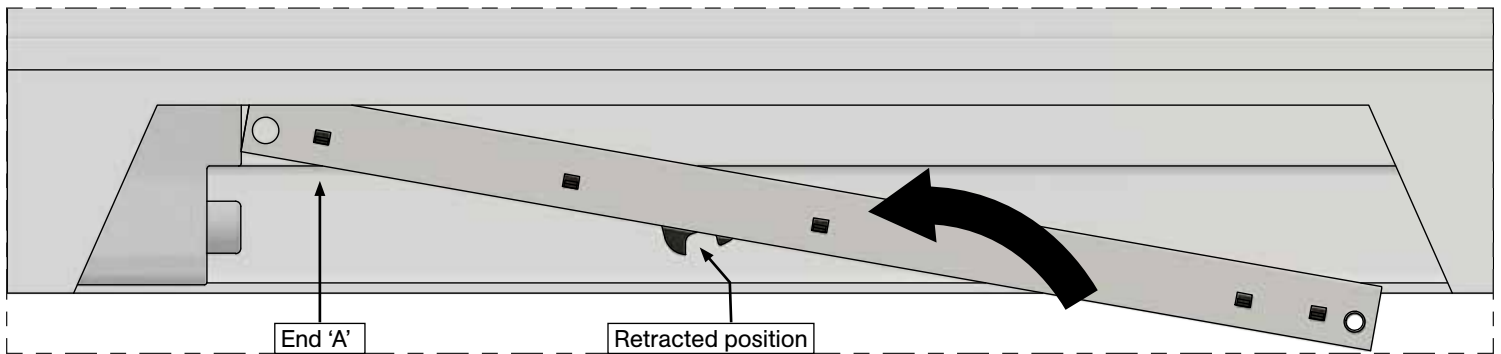
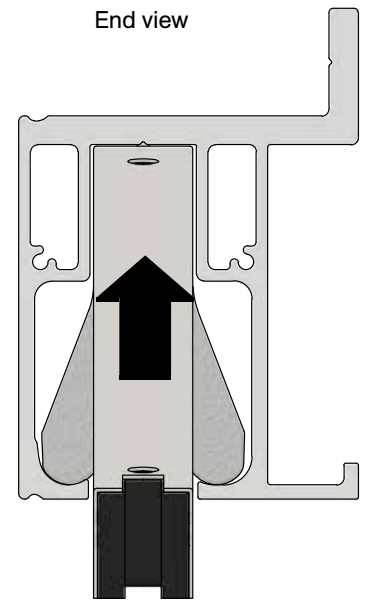
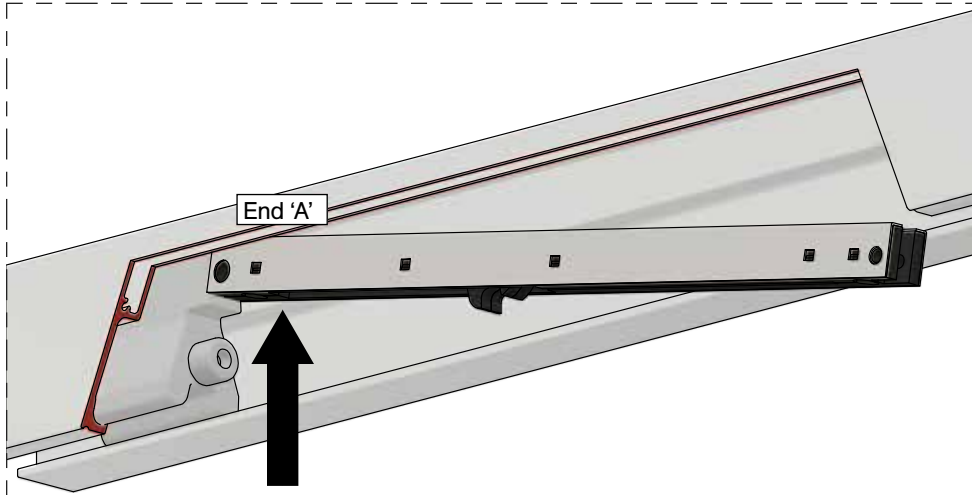

Step #20:

Secure Catch 'N' Close Device to track with two (2) #10 x 1-1/2" Self-Drilling Screws [FT5]. Repeat for opposite end with Catch 'N' Close Device installed in reverse as shown on front page in "Elevation View" illustration.

Note: if using impact driver to secure Catch 'N' Close Devices, do not overtighten screws. It is recommended to pre-drill track with Ø9/64 in [3.6 mm] drill bit. Secure first screw closest to CC-101HD Stop only and test system by sliding door to activate Catch 'N' Close. If in correct position, secure with second screw. Remove any drill fillings from inside track.

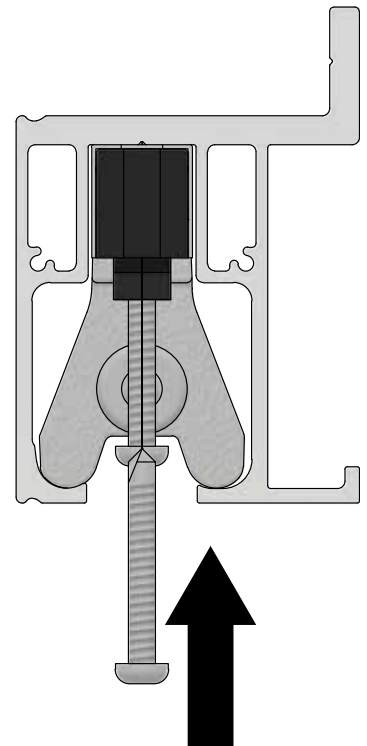
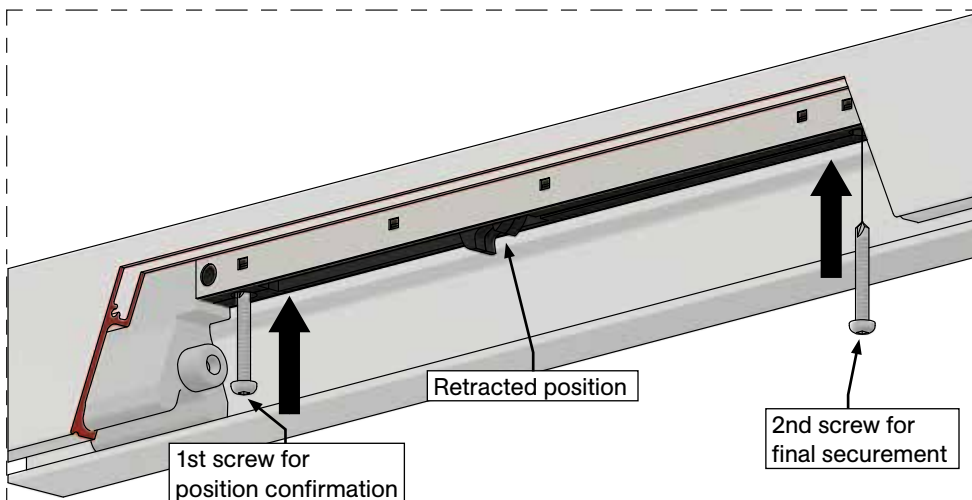

Step #21:

Test complete Catch 'N' Close system by sliding door to both left and right to activate closing devices.

CC-990 Fascia and CC-991 End Cap Installation

Step #F1:

Cut CC-990 Fascias to match track length.

Step #F2:

Lift fascia up to track and snap on as shown right.

Note: If fascia is loose, use a rubber mallet on inside leg at 24 in [610 mm] intervals to tighten fit.

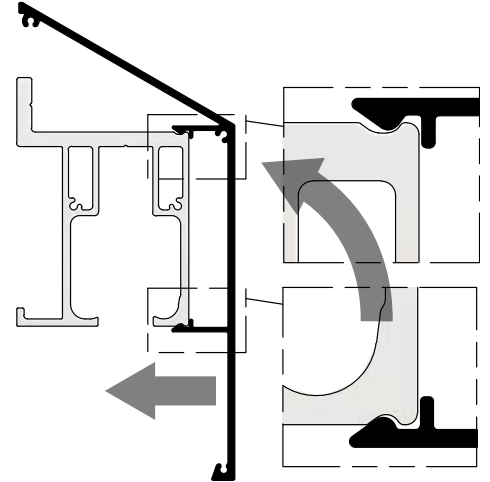
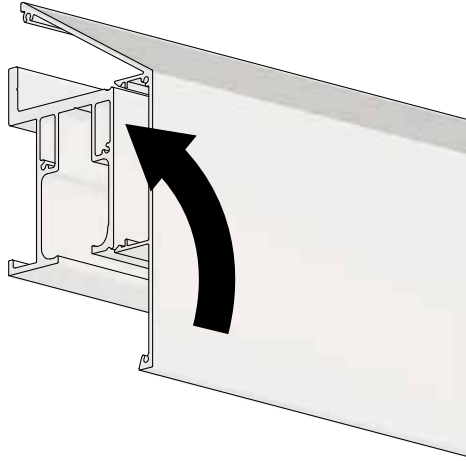

Step #F3:

Install CC-991 End Cap as shown right with the supplied #4 x 5/16" Flat Head Screws [FT29], four (4) screws per end cap provided.

Note: Do not install with impact driver.

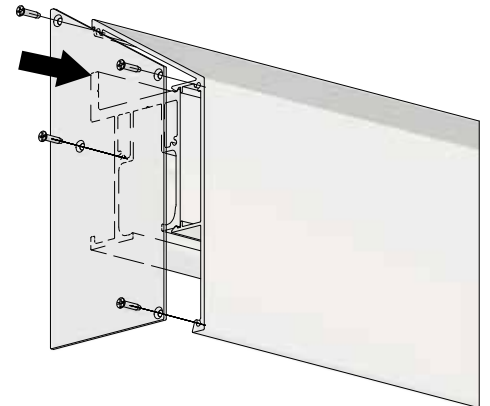

Troubleshooting

Issue	Solution
Chatter/noise when door is sliding	Ensure there are no aluminum shavings within track. Shavings can become embedded in nylon tires and cause noise during operation.
Door is hard to move	Ensure guide channel secured to bottom of door is not over-tightened as this could cause sides of guide channel to pinch guide. Remove door and check guide channel by rolling guide roller in channel to ensure smooth travel. There should be little to no resistance. Ensure door is not dragging on bottom of floor/guides and adjust height of door as required.
Door rattles	Ensure locking nuts and screws on hangers are secured and not loose.
Door is not engaging closing device	Ensure hangers are correctly oriented. See step #4 . Ensure Catch 'N' Close Devices are in correct retracted or extended position prior to sliding door closed/open. See step #18 .
Replacing the Catch 'N' Close Device	The Catch 'N' Close track and hardware system is designed for easy installation. If a closing device fails, remove the two screws holding it in place and replace the device with a new one.