

Crowder Cantilever

Square Fascia

Installation Instructions

- Designed to allow patient lift systems to seamlessly travel across doorways from one room to the next, ensuring uninterrupted operation in hospitals and assisted living facilities
- Allows sliding doors to travel across a gap in the track up to 16 in [406 mm]
- 300 lbs. [136 kg] weight capacity
- Effortless opening and closing of the door with the Catch 'N' Close Closing System
- Square fascia design for minimum and modern look
- Nylon wheels and precision ball bearings provide smooth and quiet door operation
- Flared tracks at gap ease the transition for the door crossing over
- Leading stainless steel tire on hanger for increased durability when crossing gap
- Heavy-duty double roller floor guide system ensures stability
- 3/8 in [9 mm] hanger adjustability
- Adjustable in-track stops
- Handed openings
- Cycle tested for up to 150,000 cycles without fail
- ADA Compliant (Barrier-free) design
- Available in clear or black anodized, mill finish or powder coated
- Minimum 1 3/4 in [44.5 mm] thick doors

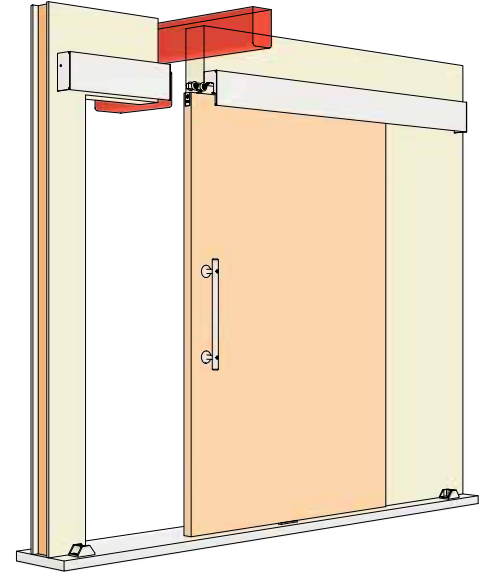

Table of Contents

How It All Comes Together

- 2 How It All Comes Together

Product Details & Dimensions

- 3 Section View
4 Elevation View
4 Plan View
6 Parts List

Installation

- 8 General Installation
21 Troubleshooting
22 Alternative Door Installation (Limited Space)

How It All Comes Together

Note: Details are shown as **Right-hand Outside [RHO]** opening format

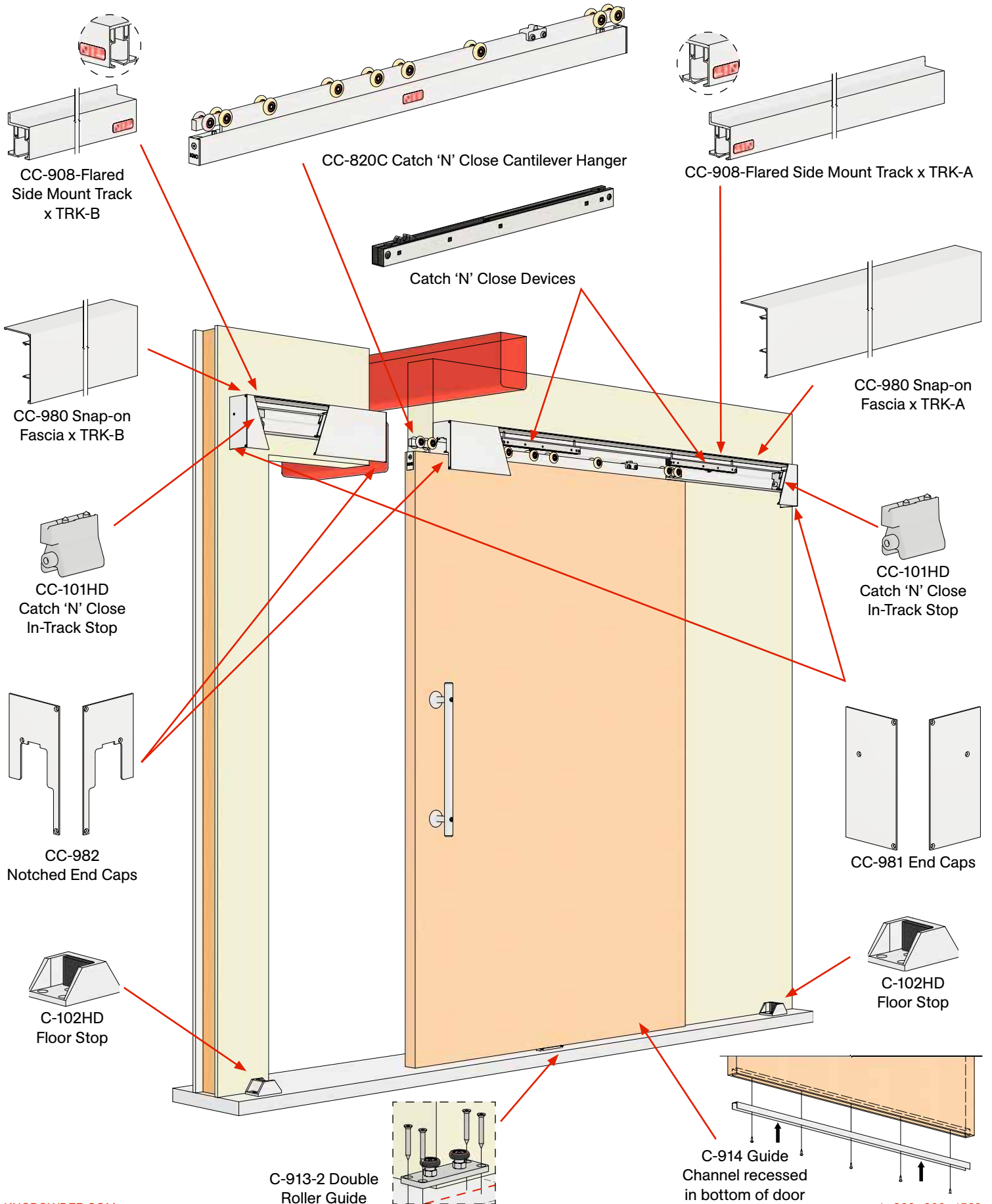

Product Details & Dimensions

Note: Details are shown as **Right-hand Outside [RHO]** opening format

Section View

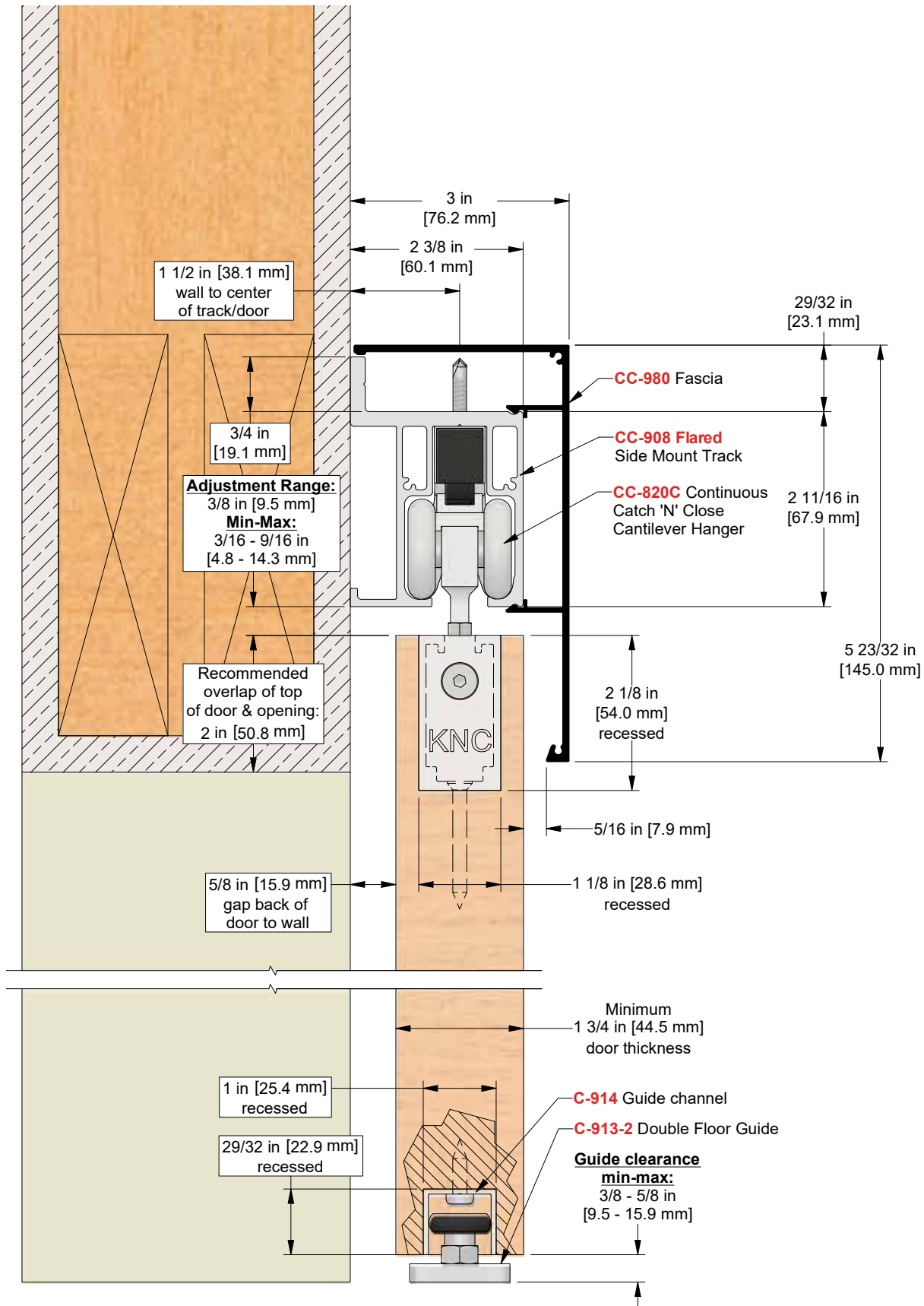

Product Details & Dimensions

Note: Details are shown as **Right-hand Outside [RHO]** opening format

ELEVATION VIEW - OPEN POSITION

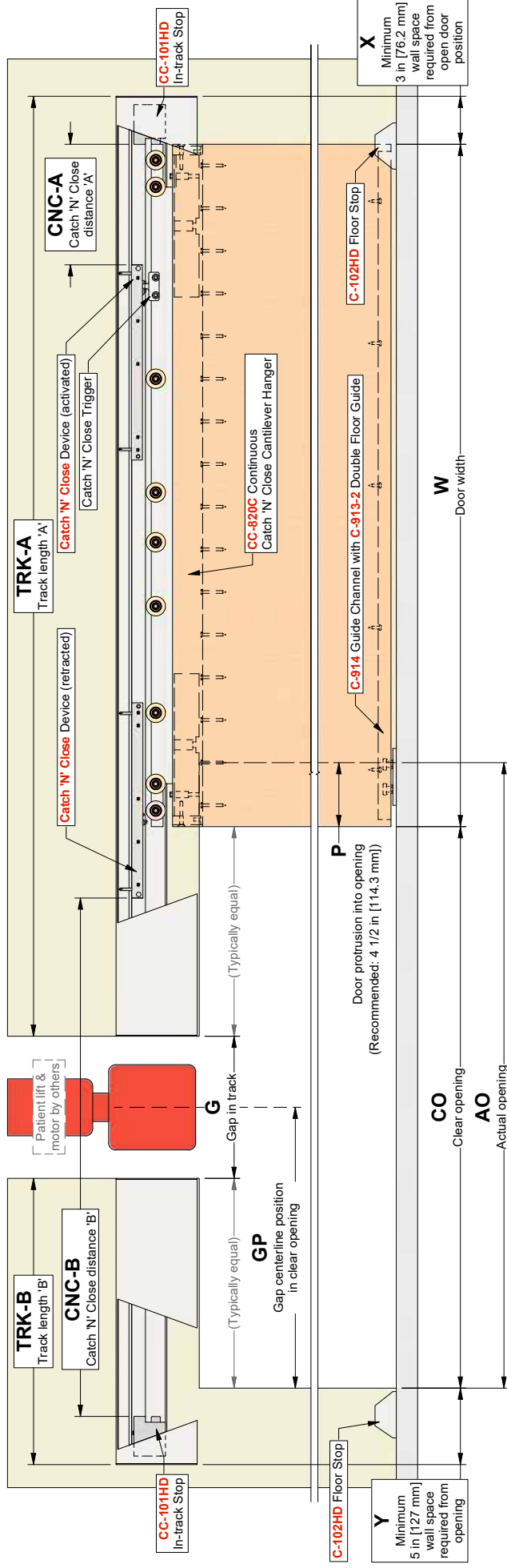

PLAN VIEW - OPEN POSITION

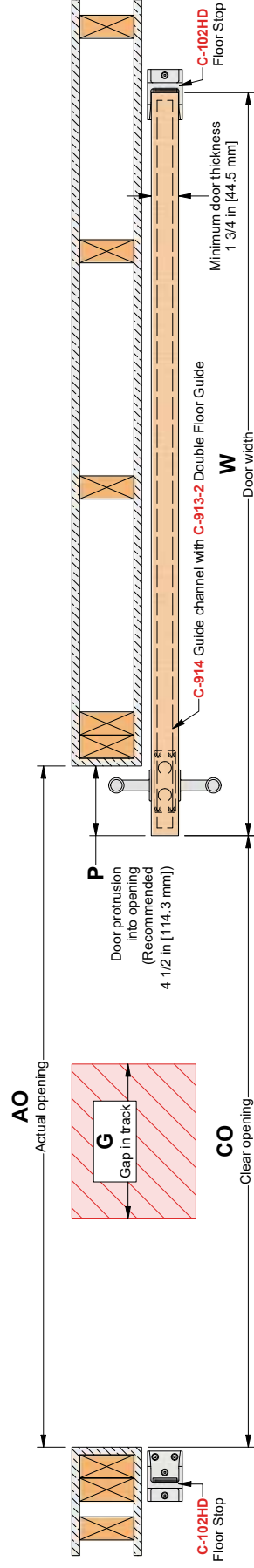

Note: Details are shown as Right-hand Outside [RHO] opening format

ELEVATION VIEW - CLOSED POSITION

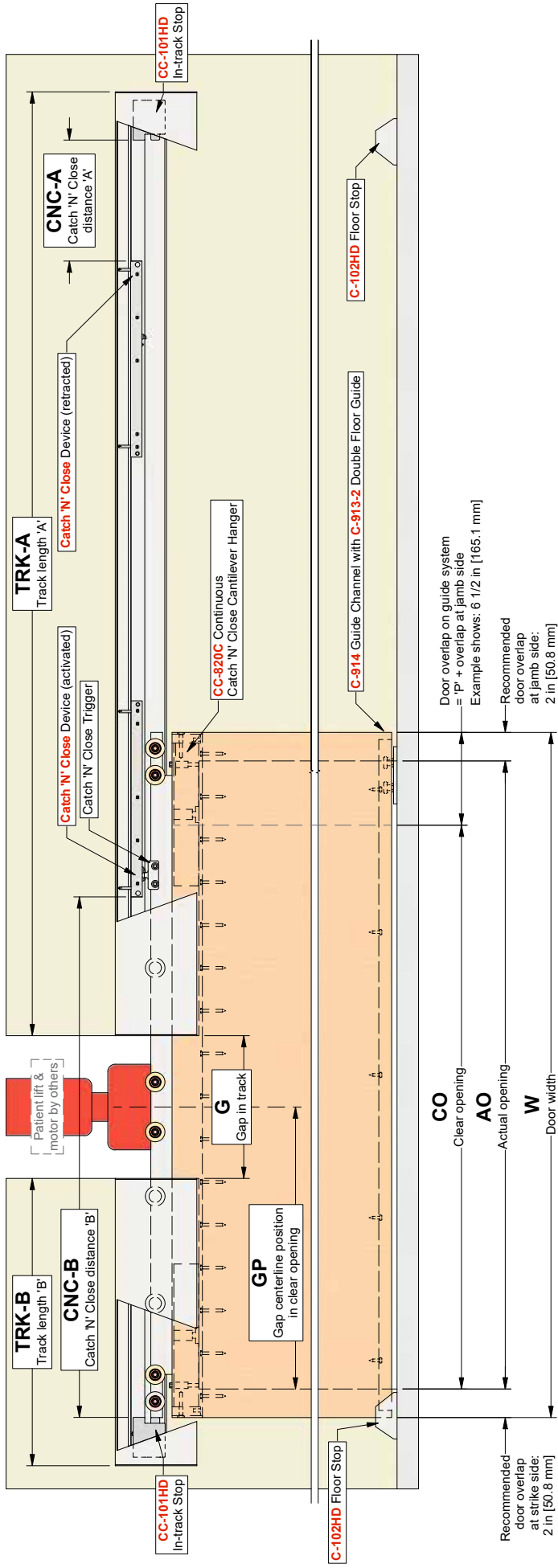

PLAN VIEW - CLOSED POSITION

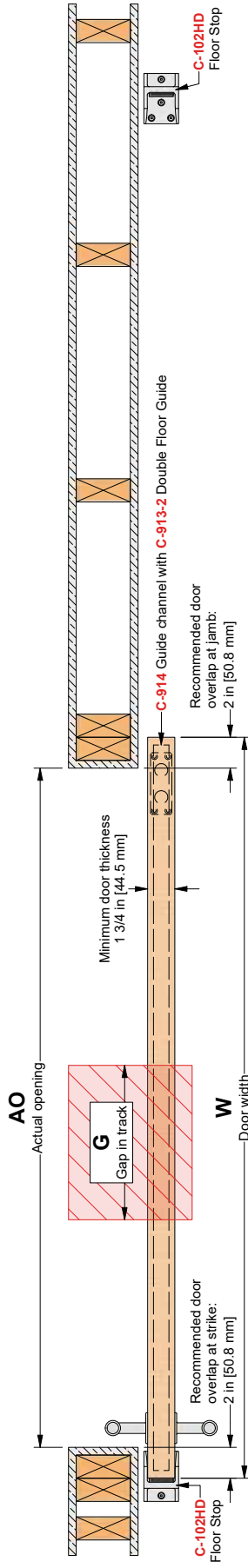

Parts List

Note: Details are shown as **Right-hand Outside [RHO]** opening format

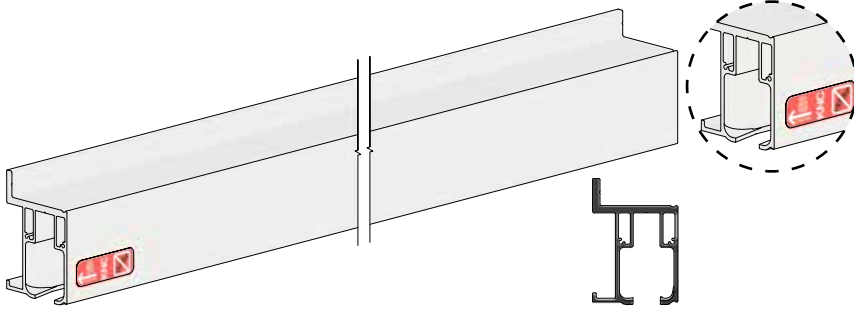

CC-908-Flared Side Mount Track x TRK-A (1)
TRK-A length per layout drawing

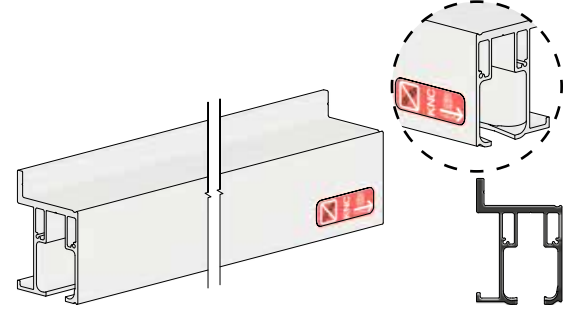

CC-908-Flared Side Mount Track x TRK-B (1)
TRK-B length per layout drawing

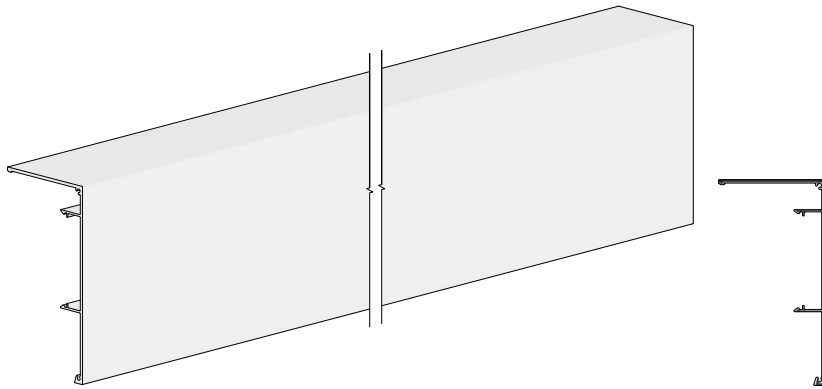

CC-980 Snap-on Fascia x TRK-A (1)
TRK-A length per layout drawing

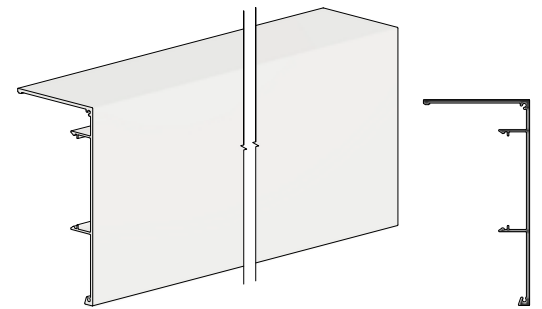

CC-980 Snap-on Fascia x TRK-B (1)
TRK-B length per layout drawing

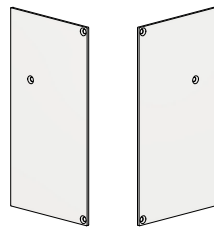

CC-981 End Caps (2)
Left and right

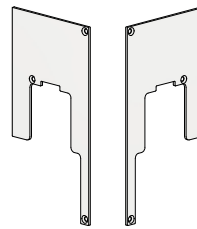

CC-982 Notched End Caps (2)
Left and right

#4 x 5/16 Flathead Screws (12)
[FT29]

CC-820C Cantilever Tool Pack (1)

One tool pack supplied for every 10 hangers. Includes:



Cantilever Project/Opening Specific Layout Drawing



CNC-A Locator Tool x CNC-A (1)
CNC-A length per layout drawing

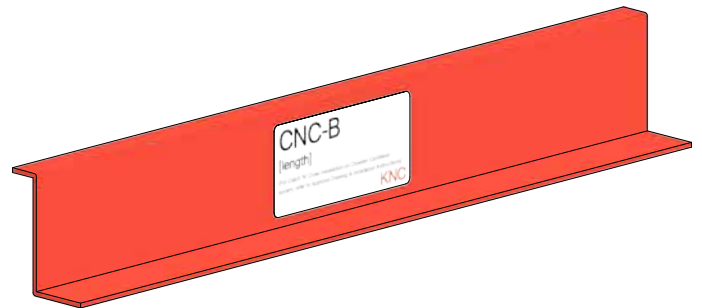

CNC-B Locator Tool x CNC-B (1)
CNC-B length per layout drawing



KNC-UW Universal Wrench (1)

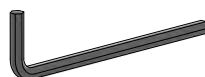

1/4" Allen Key (1)



5/32" Allen Key (1)

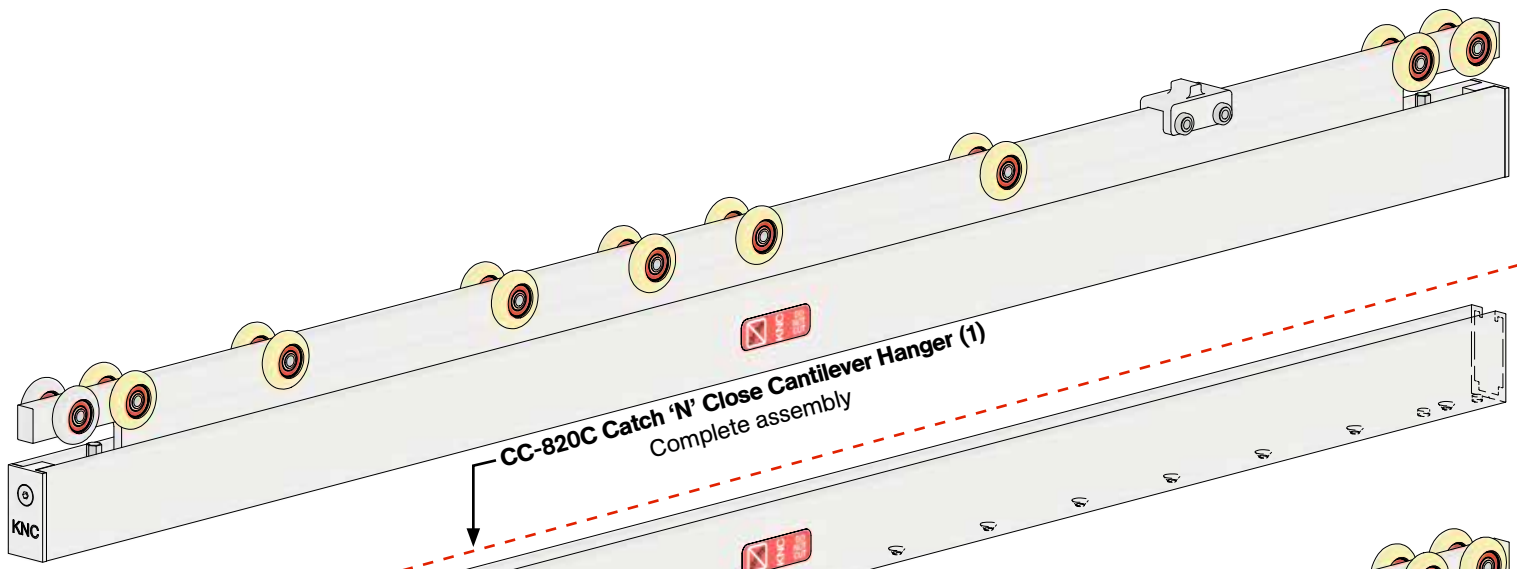

CC-820C Catch 'N' Close Cantilever Hanger (1)
Complete assembly

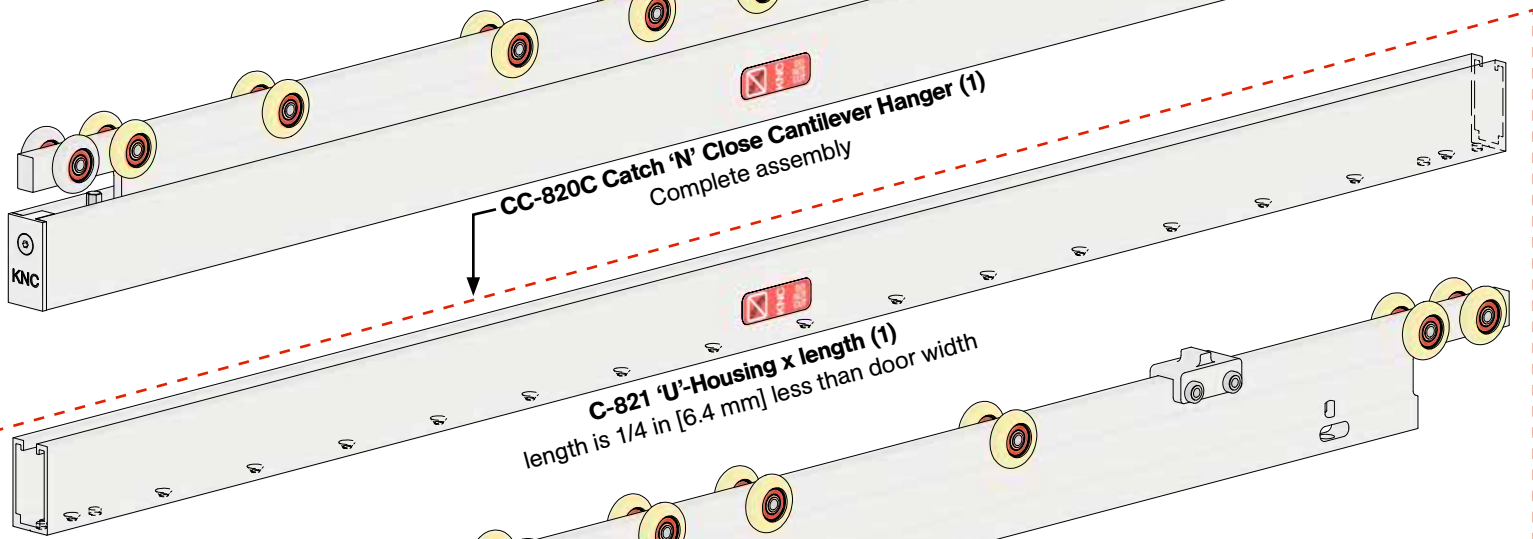

C-821 'U'-Housing x length (1)
length is 1/4 in [6.4 mm] less than door width

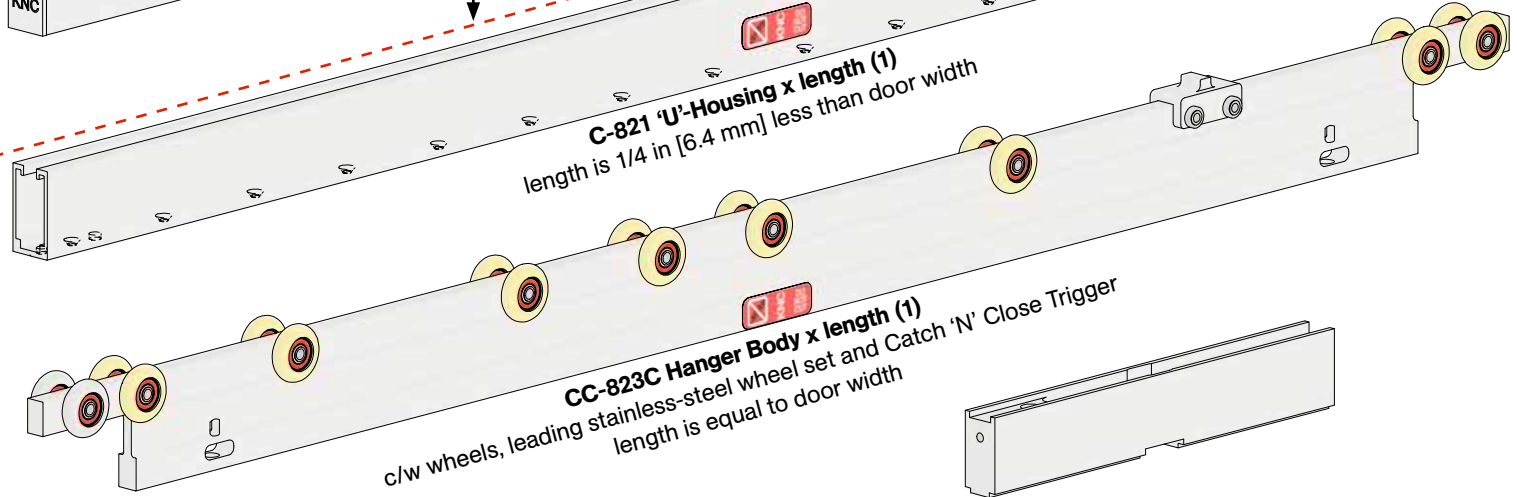

C-823C Hanger Body x length (1)
c/w wheels, leading stainless-steel wheel set and Catch 'N' Close Trigger
length is equal to door width

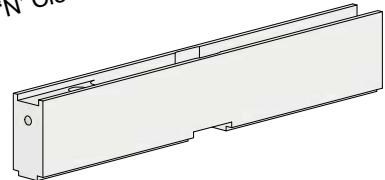

C-822 Adjustment Bars (2)



C-824 Adjustment Bolts (2)



3/8-16 Square Nuts (2)
[FT61]



C-826 Safety Lock Bolts (2)

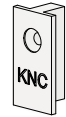

C-825 End Caps (2)



1/4-20 x 1-1/4" Flathead Socket Cap Screws (2)
[FT41]



#10 x 1-3/4" Flathead Screws (qty based on hanger length)
[FT9]

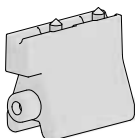

CC-101HD Catch 'N' Close In-Track Stops (2)

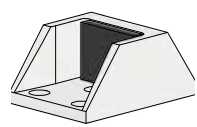

C-102HD Floor Stops (2)



#10 x 1-3/4" Flathead Screws (4)
[FT9]



Catch 'N' Close Devices (2)
See details in instruction steps

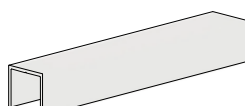

C-914 Guide Channel x length (1)

Length = door width
Example: 48 in [1220 mm] door = 48 in [1220 mm] guide channel
less set-backs if desired



#8 x 3/4" Pan Head Screws (8)
[FT2]

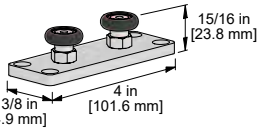

C-913-2 Double Floor Guide (1)



#10 x 1-1/2" Self-Drilling Screws (4)
[FT5]



#10 x 1-1/2" Flathead Screws (4)
[FT7]

Installation Steps

Note: Details and step illustrations show a typical installation using **Right-hand Outside (RHO)** opening set-up.

Step #1:

Determine door size, header height, track position, and bottom clearance based on kit code ordered by using dimensions shown in detail views on previous page.

Step #2:

Cut CC-908 flared aluminum tracks to size if required. One long length, 'TRK-A,' and short length, 'TRK-B,' are supplied based on customer-approved, project-specific layout drawing by KNC.

Note: One end of each length has a flared profile, identified by sticker.

Please do NOT cut these ends as flared ends are required for easy transition of hanger across gap.

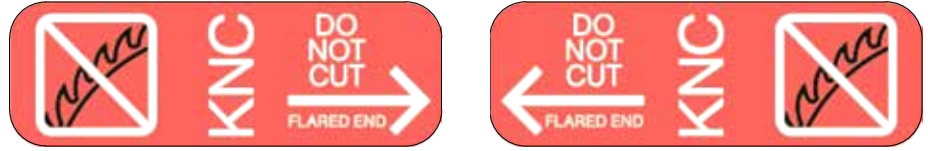

Holes are not pre-drilled and must be marked and drilled by installer.

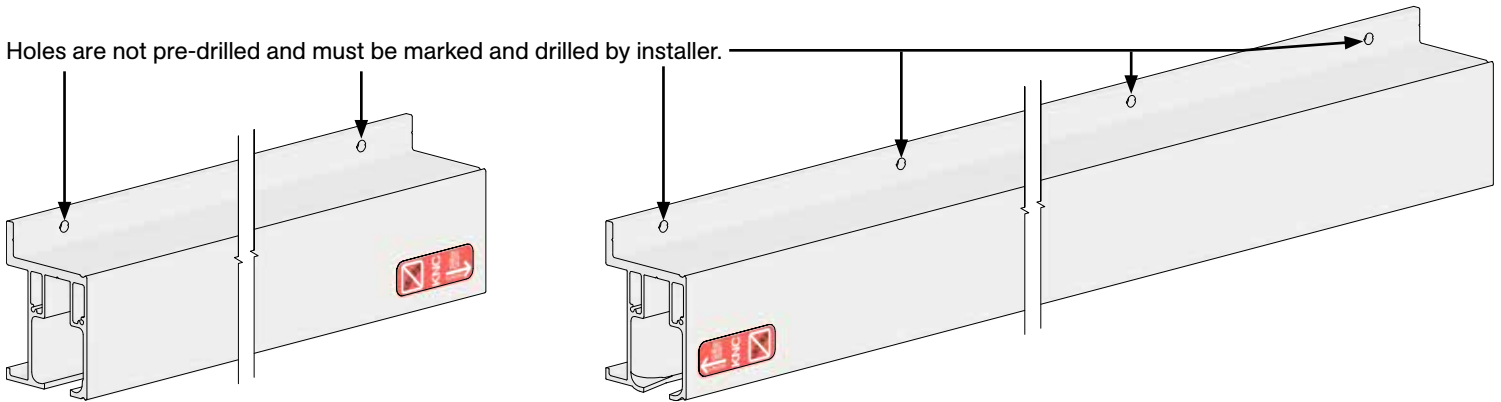

Step #3:

Locate and pre-drill holes in mounting flange on track. Secure tracks to structural support/backing, ensuring flared ends meet in gap opening and tracks are level with one another.

Note: Solid backing is required. Recommended to use 5/16 in [7.9 mm] diameter lag or structural bolts to secure track. Spacing is recommended to be between 12-16 in [304-406 mm] on center. Consult structural engineer to ensure adequate support and fastening. If track with fascia and end caps are required to be flush with gap opening, set tracks back 1/16 in [1.6 mm] from gap opening.

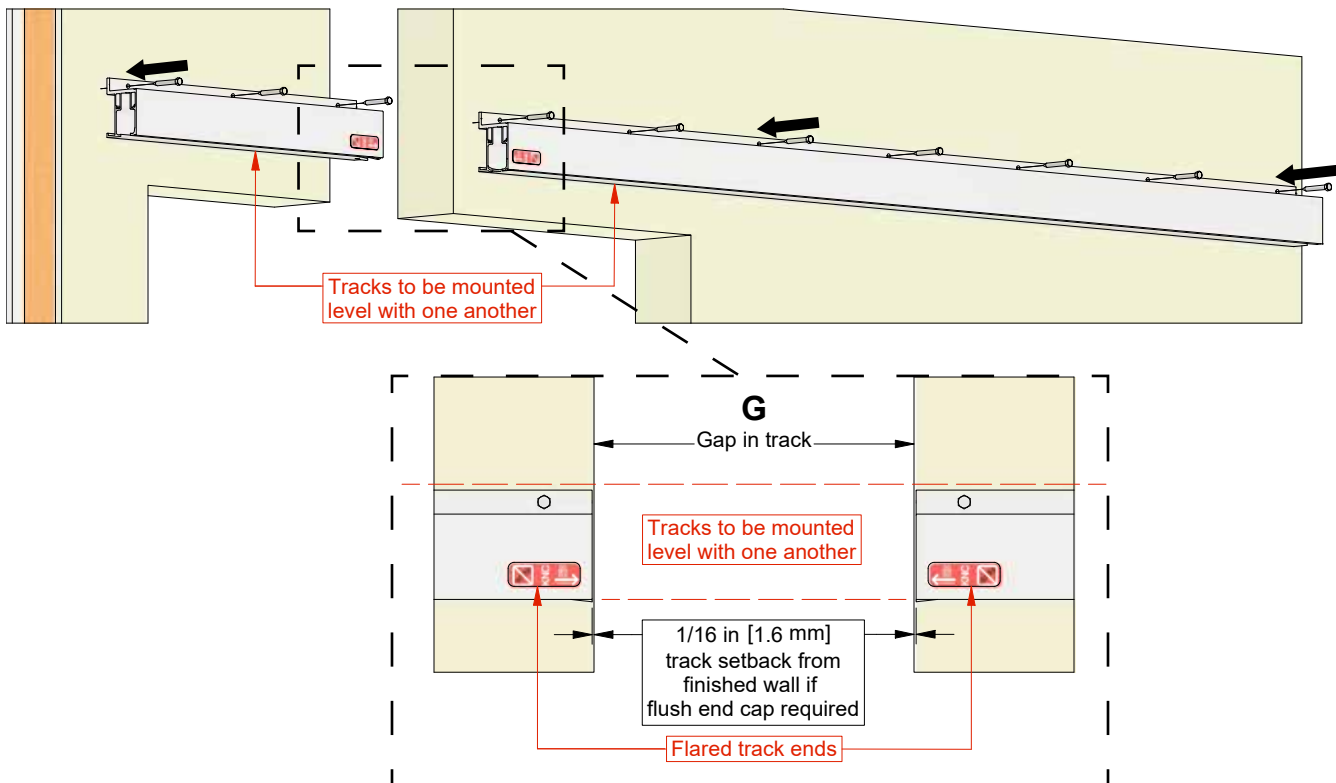

Step #4:

Disassemble CC-820C Catch 'N' Close Cantilever Hanger:

Fig. 1 Remove 1/4-20 x 1-1/4" Flathead Socket Cap Screw [FT41] with supplied 5/32" Allen Key, lift out C-825 End Cap and loosen C-826 Safety Lock Bolt with supplied KNC-UW Universal Wrench. Repeat on opposite end.

Fig. 2 Slide complete CC-820C Upper Hanger Assembly out of C-821 'U'-Housing.

Fig. 3 Complete CC-820C Upper Hanger Assembly and C-821 'U'-Housing shown.

Note: Do NOT disassemble CC-820C Upper Hanger Assembly any further.

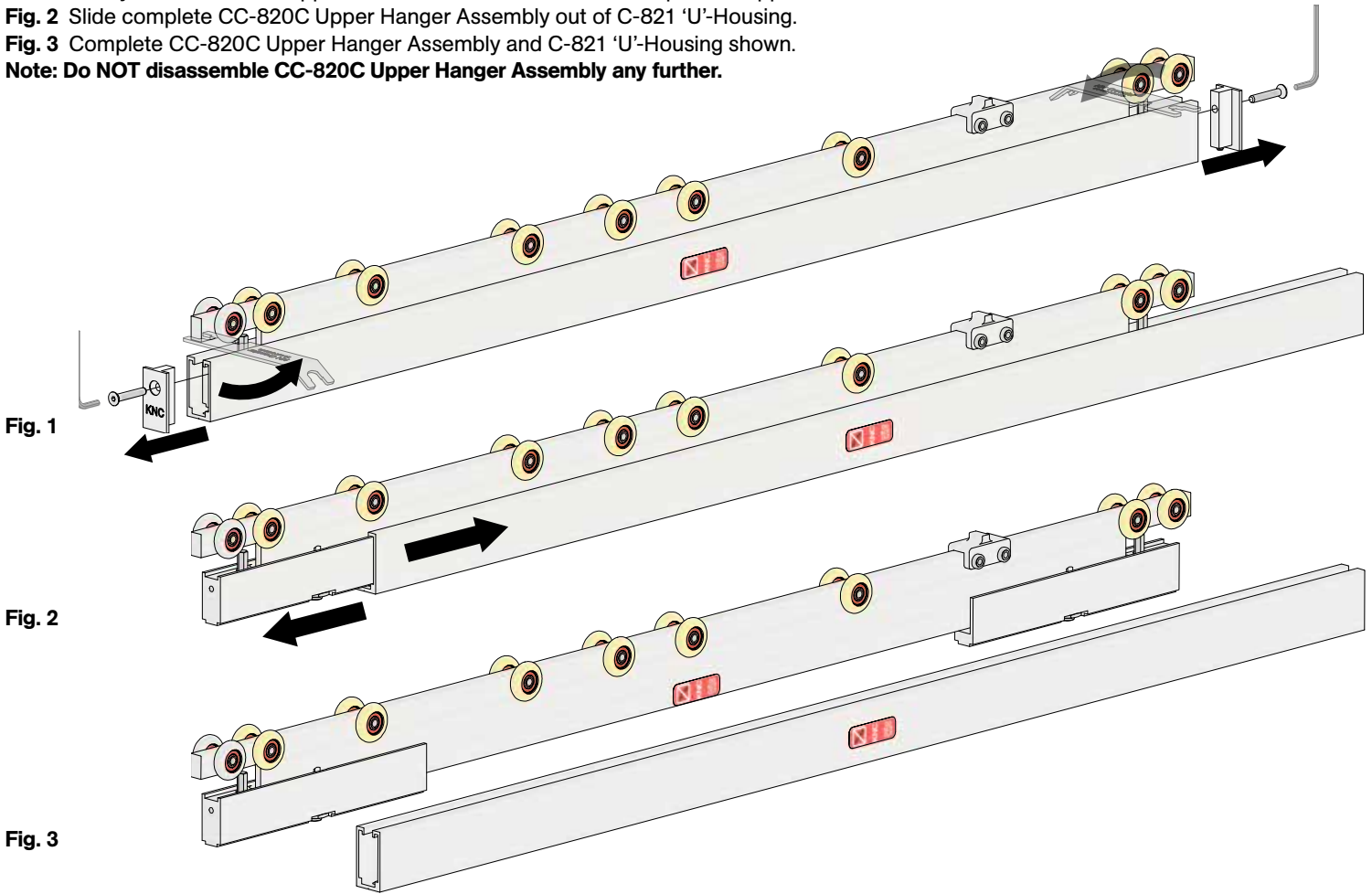

Step #5:

Prepare door to receive:

C-821 'U'-Housing slot flush with top edge of door: 1 1/8 in [28.6 mm] wide x 2 1/8 in [54.0 mm] deep x full width of door.

C-914 Guide Channel slot in bottom of door: 1 in [25.4 mm] wide in center of door, 29/32 in [22.9 mm] deep and set back 1/2 in [12.7 mm] from both edges of door. Make slot as accurate as possible for secure fit and neat appearance.

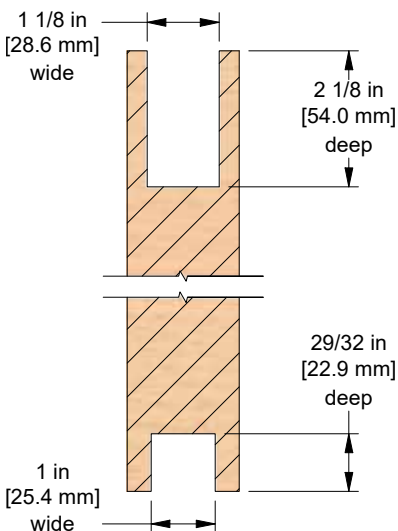

Note: If door has sufficient overlap, guide channel can be recessed into door without cutting a full-length slot in door. If guide channel will be fully recessed, it is recommended to have at least 1/2 in [12.7 mm] door material at each end of door before start of guide channel slot.

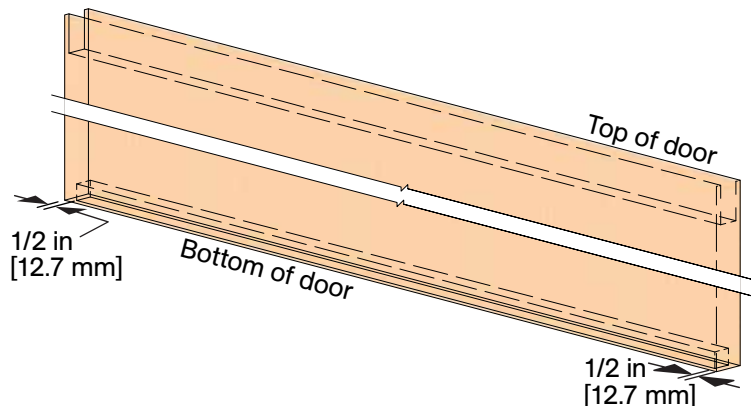

Step #6:

Place C-821 'U'-Housing into slot created in **step #5** ensuring 1/8 in [3.2 mm] setback from each edge is maintained. Secure to door with #10 x 1-3/4" Flathead Screws [FT9]. Use C-825 End Cap as measurement indication if needed.

Note: Do NOT cut C-821 'U'-Housing as it has been specifically machined to receive Upper Hanger Assembly. If there is an issue with size, please contact KN Crowder for assistance.

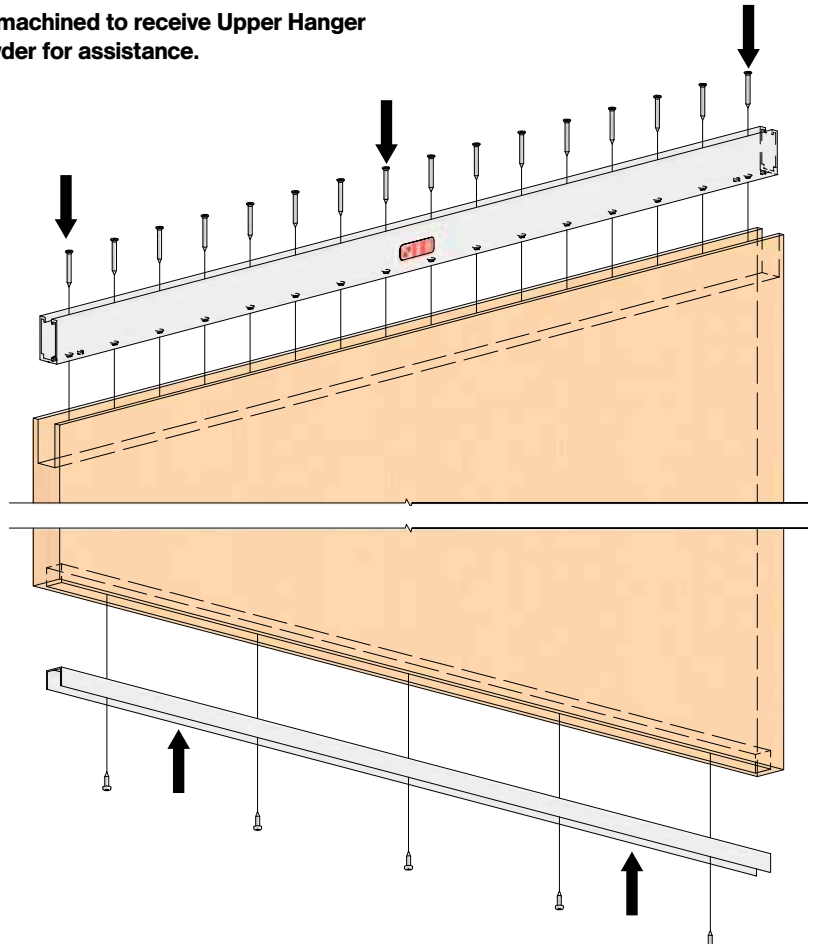
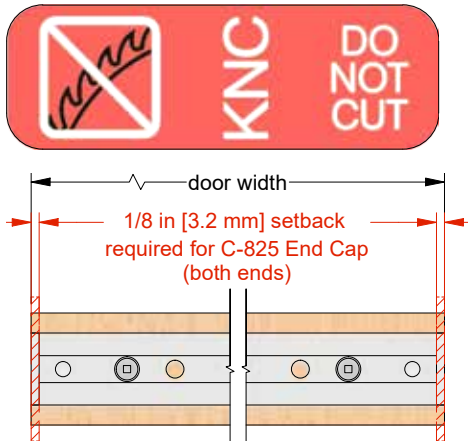

Step #7:

Cut C-914 aluminum guide channel to correct length as required. Drill holes in C-914 Guide Channel and pre-drill holes in door. Locate C-914 Guide Channel in slot and secure channel into place with (up to 8) #8 x 3/4" Pan Head Screws [FT2].

Step #8:

Using a plumb line on centerline of track above, mark centerline on floor. Ideally if wall is plumb, centerline will be 1 1/2 in [38.1 mm] from wall, assuming no baseboard. Review project/opening specific layout drawing for overlap space for guide to be positioned accordingly. Secure guide to floor with two (2) #10 x 1-1/2" Flathead Screws [FT7] to allow for adjustments after door is hung. Once guide's position is confirmed, install remaining two screws for a total of four (4). Alternatively, guide can be installed after door is hung for more accurate positioning, but if so, door will need to be taken down to install guide and re-hung.

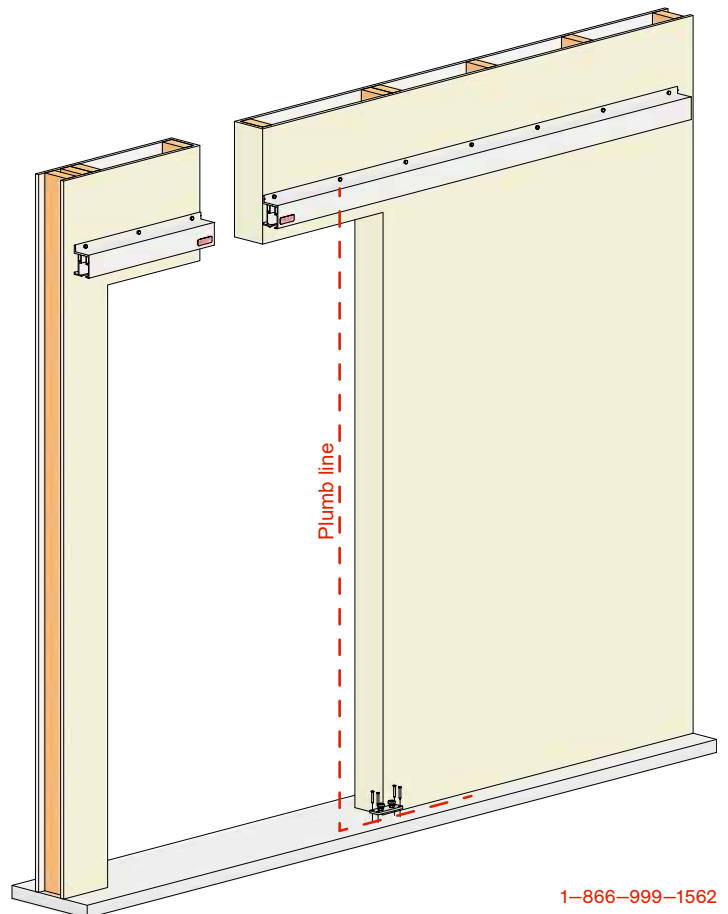
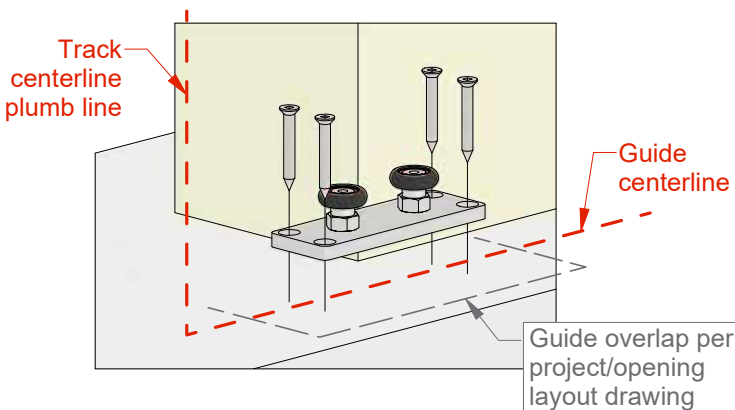

Step #9:

Raise door, and position over guide.

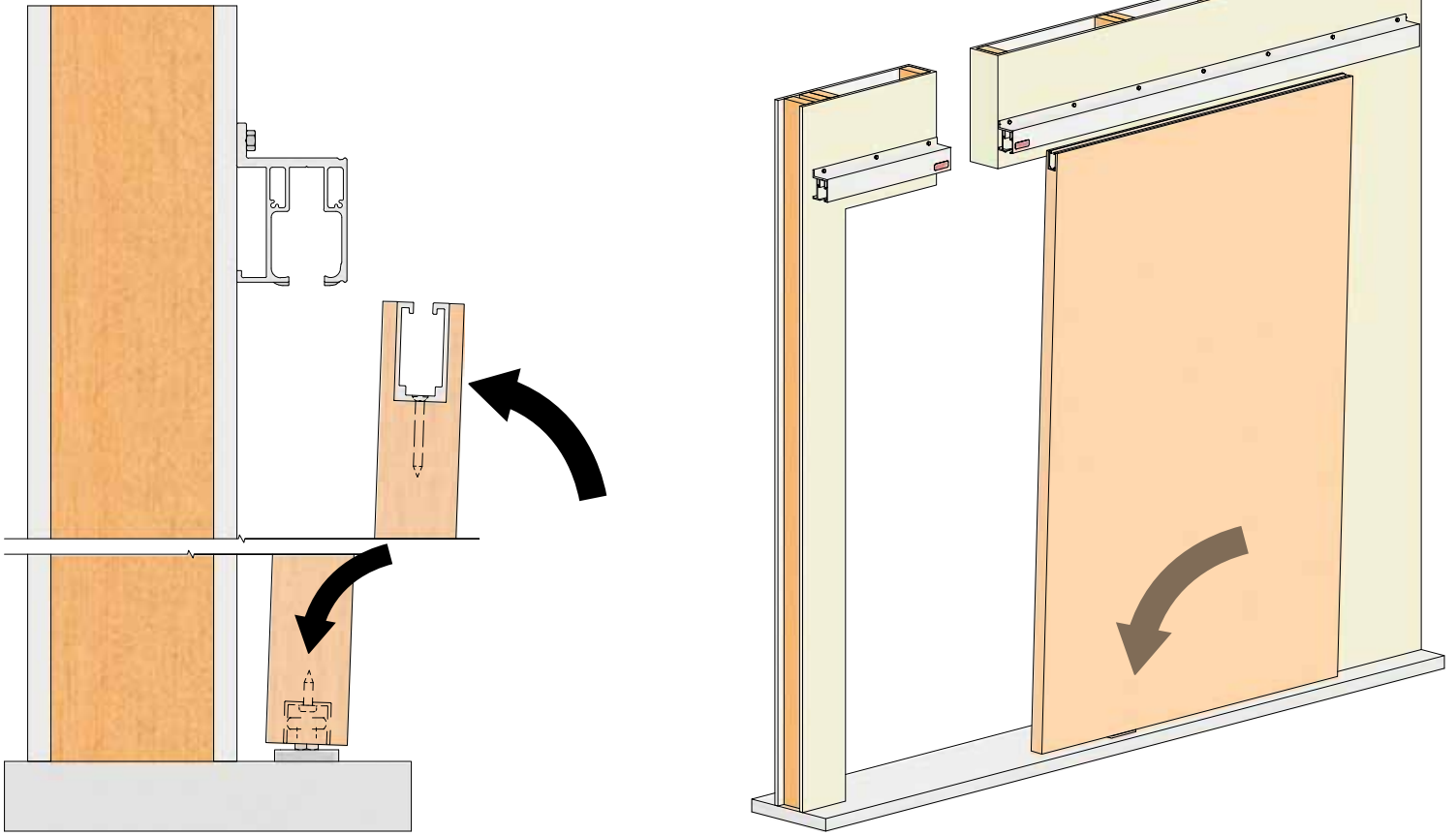

Step #10:

Slide complete CC-820C Upper Hanger Assembly into tracks from either left side or right side, shown below.

Note: Ensure leading edge of hanger assembly, which is identified by the set of stainless-steel wheels, is positioned so it will cross over the gap first when sliding the door closed. If space is not available on either side of track for this process, please refer to steps #A1-A6 found on pages 22-24.

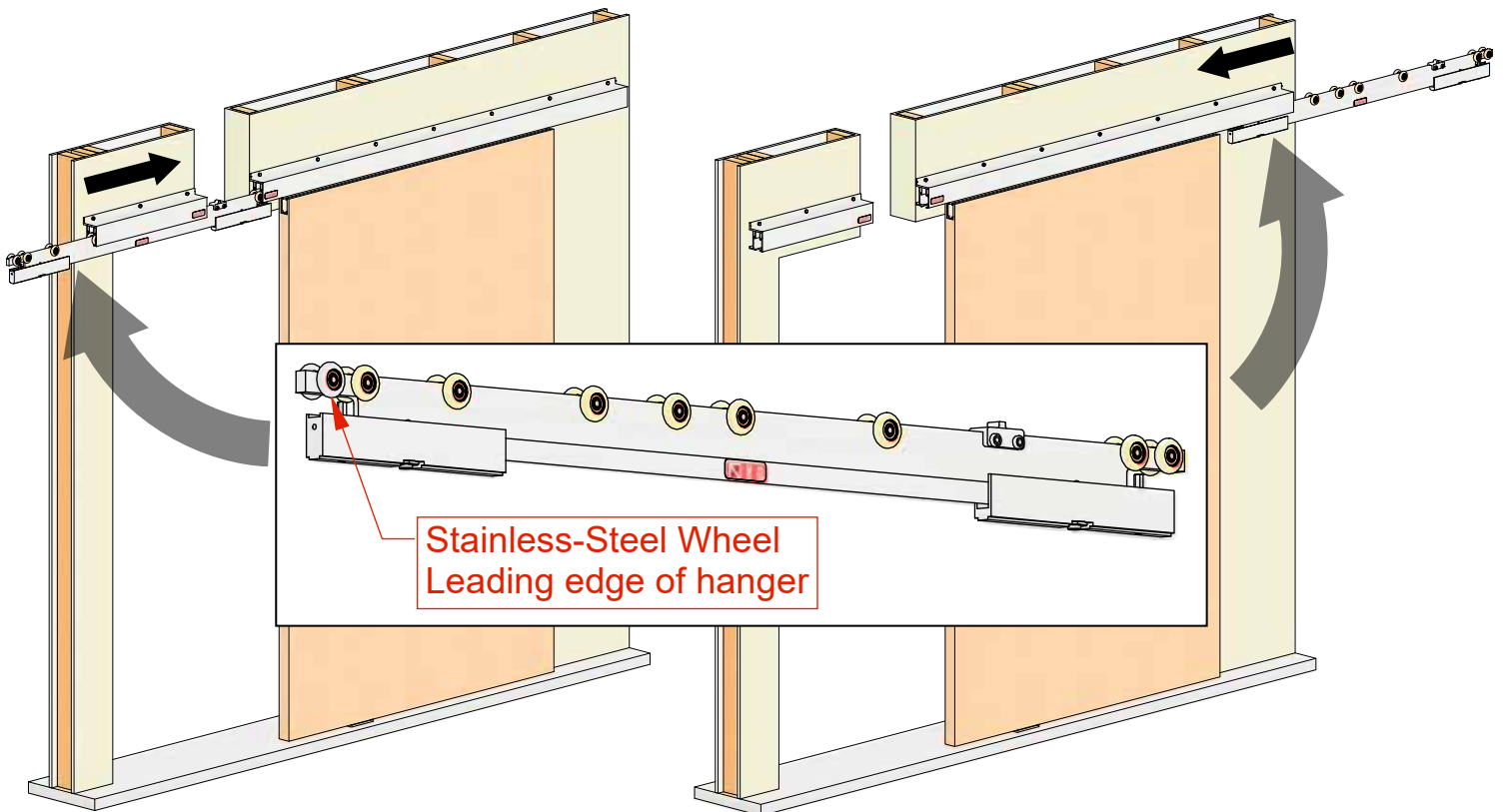

Step #11:

Slide CC-820C Upper Hanger Assembly fully into C-821 'U'-Housing Channel on door and ensure the large hex mid-section on C-824 Adjustment Bolt is orientated to slide into channel.

Note: The purpose of hex mid-section is to prevent rotation of bolt therefore securing height adjustment.

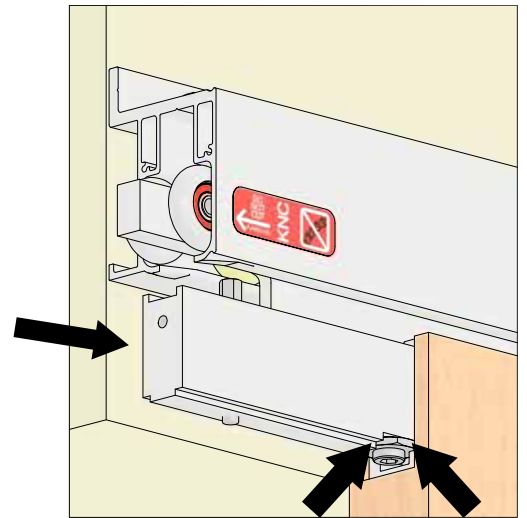
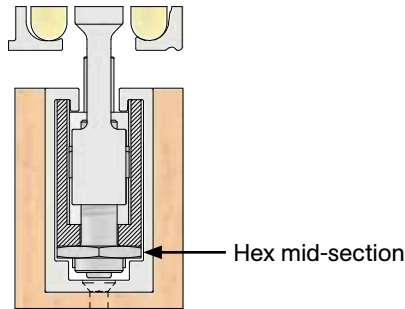
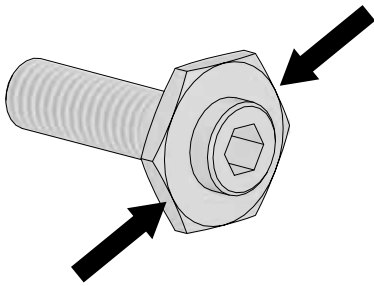

Step #12:

Check door height and plumb. To adjust, slide CC-820C Upper Hanger Assembly out one side of the door about 7 in [178 mm] in order to expose C-824 Adjustment Bolt. Using the 1/4" Allen Key supplied, adjust as required, repeat on other side if needed until required height and plumb is achieved.

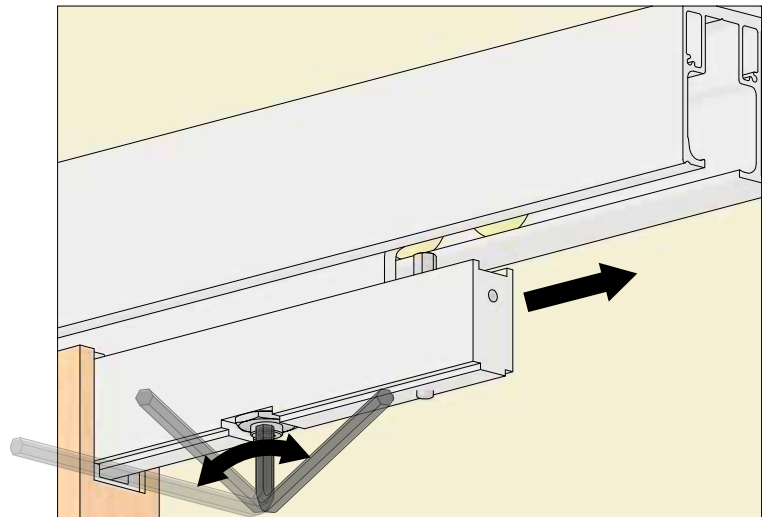
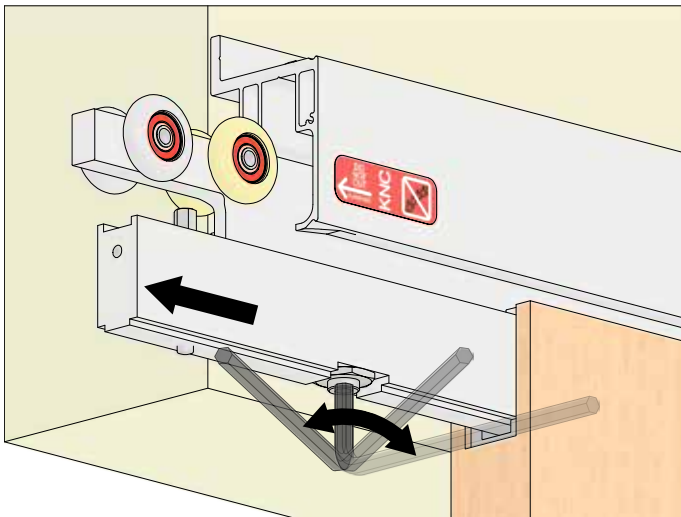

Step #13:

Once adjustments have been finalized, position CC-820C Upper Hanger Assembly equal distance from each edge of the door or ensure overall length and upper body portion with wheels inside track, lines up with edges of door. Secure C-826 Safety Lock Bolts on both ends of hanger using KNC-UW Universal Wrench.

Note: this custom bolt has been manufactured to engage a pre-drilled position in the C-821 'U'-Housing to prevent accidental disengagement. See detail 13A in step #14 for section view of the C-826 Safety Lock Bolt locked into C-821 'U'-Housing.

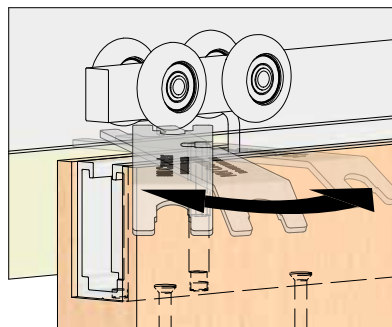
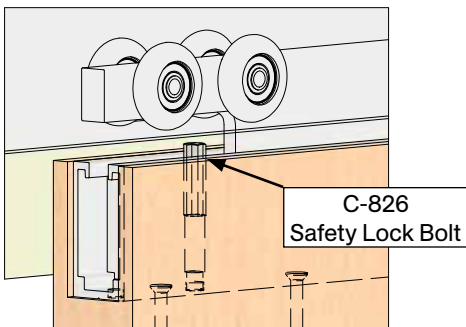

Step #14:

Install C-825 End Caps on both ends of hanger with lower pin engaging the hole in the bottom of the C-821 'U'-Housing. Secure End Caps with 1/4-20 x 1-1/4" Flathead Socket Cap Screw [FT41] by using 5/32" Allen Key.

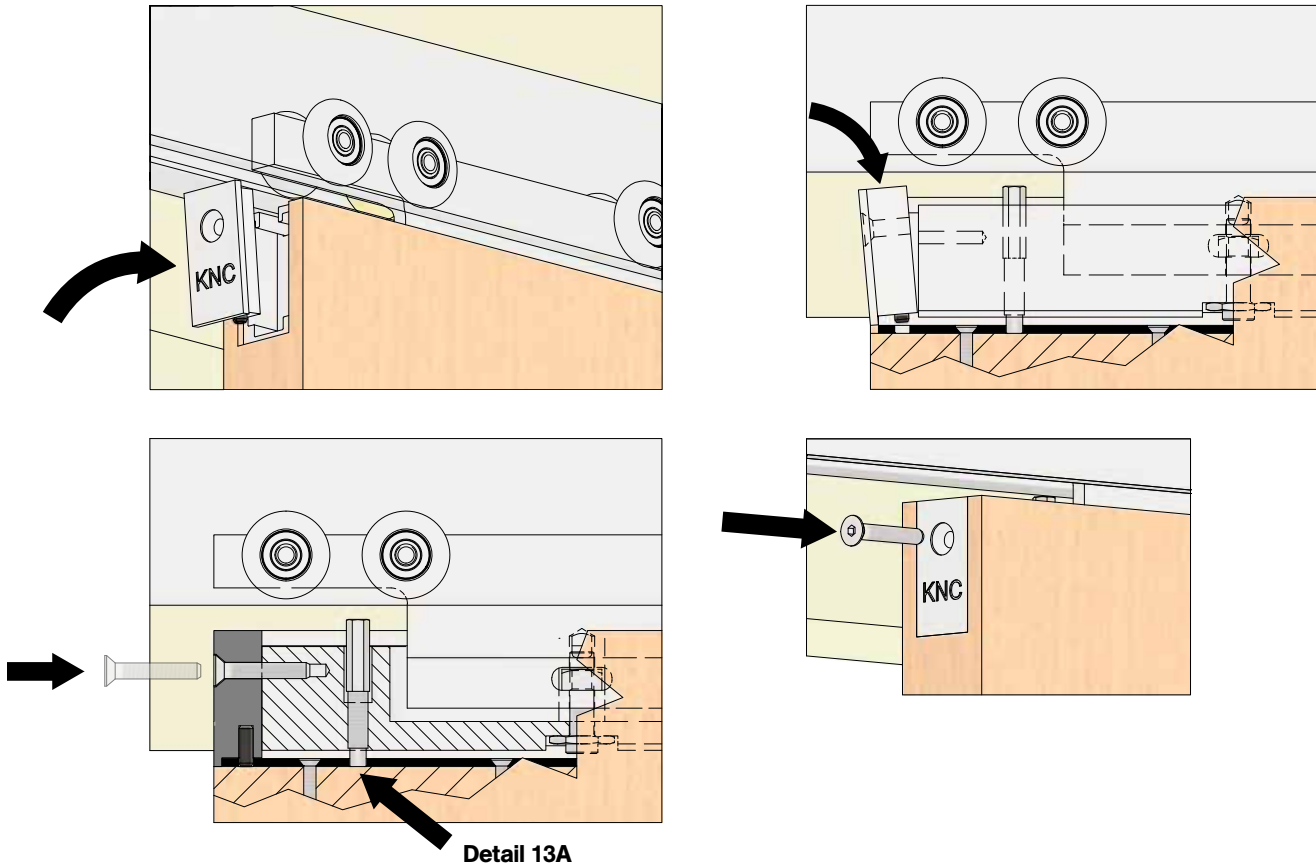

Step #15:

After door is installed, slide a CC-101HD In-Track Catch 'N' Close Stop into each outside end of track.

Note: If no space is available at outside ends of track for this process, stop for shorter track can be slid in through gap in track. For opposite end, stop should be installed during door and track installation process, as outlined in steps #A1 - A6 on pages 22-24.

Illustration below shows correct positioning of stops in track

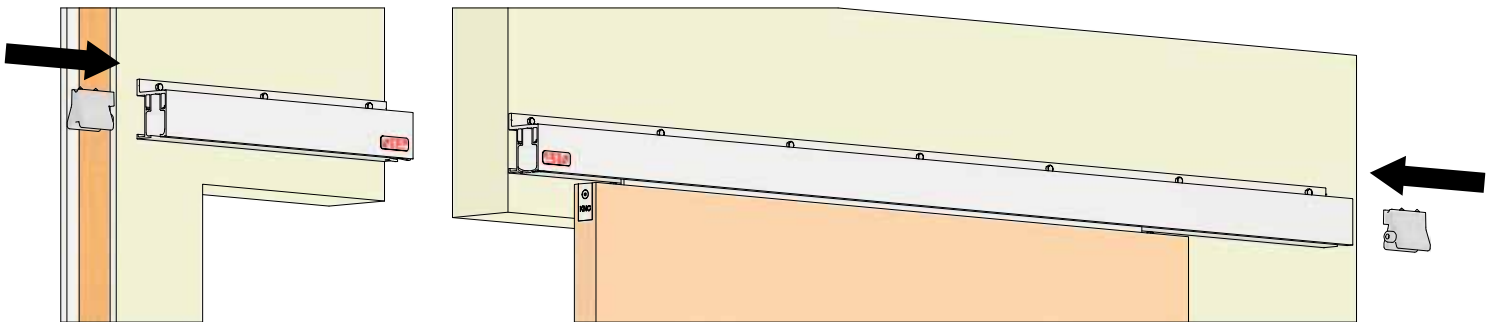
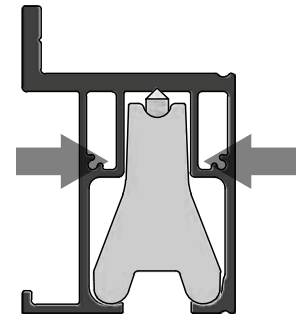

Step #16:

After door has been installed, position door approximately 5-10 in [127-254 mm] away from approximate open position, shown below on right side. Push loose CC-101HD Stop against upper hanger body.

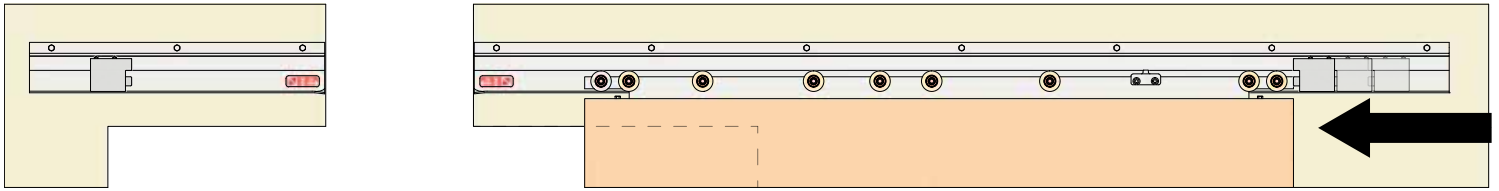

Step #17:

With CC-101HD Stop loose, slide door to final/desired position as shown below.

Note: Ensure that door protrusion and any finishing trim thicknesses are taken into consideration for final/desired position of door.

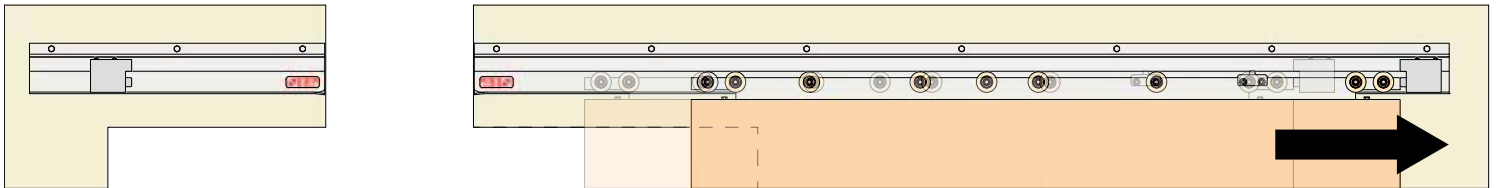

Step #18:

Once final position is achieved, slide door away from CC-101HD Stop. Lock CC-101HD Stop in position by tightening two (2) cap screws on CC-101HD Stop with 3/16 in Allen Key. CC-101HD is secured by friction fit with cone point screws.

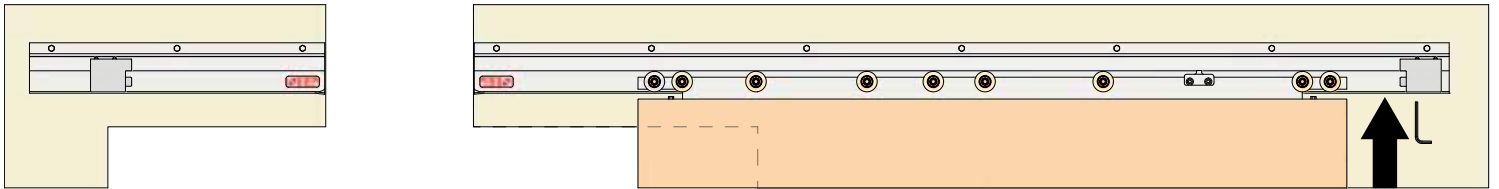

Step #19:

Position door approximately 5-10 in [127-254 mm] away from approximate closed position, shown below on left side. Push loose CC-101HD Stop against upper hanger body.

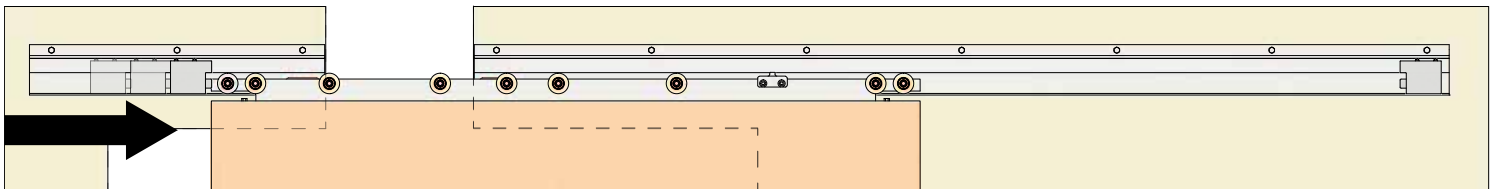

Step #20:

With CC-101HD Stop loose, slide door to final/desired position.

Note: Ensure that door overlap and any finishing trim thicknesses on strike side are taken into consideration for final/desired position of door.

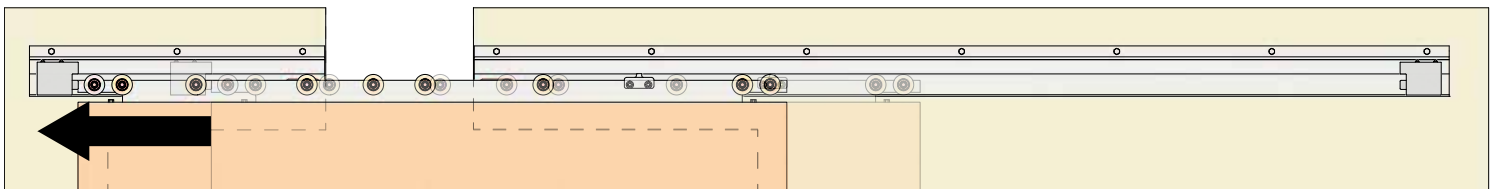

Step #21:

Once final position is achieved, slide door away from CC-101HD Stop. Lock CC-101HD Stop in position by tightening two (2) cap screws on CC-101HD Stop with 3/16 in Allen Key. CC-101HD is secured by friction fit with cone point screws.

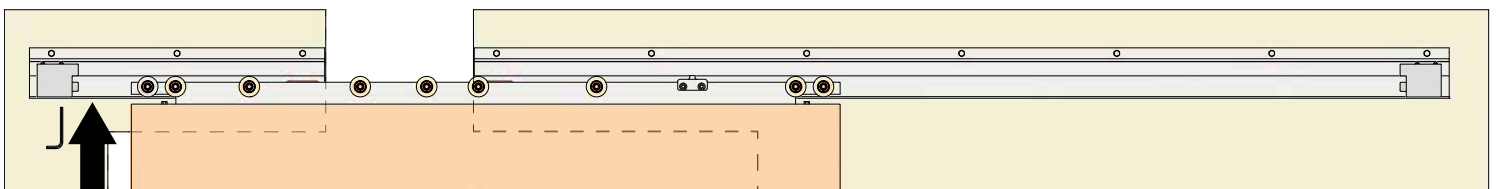

Step #22:

Position door in open position against CC-101HD Stop previously secured in **step #18**. While keeping door against CC-101HD Stop, place a C-102HD Floor Stop on the floor and position it so black bumper hits back edge of door. Mark position of C-102HD Floor Stop on floor.

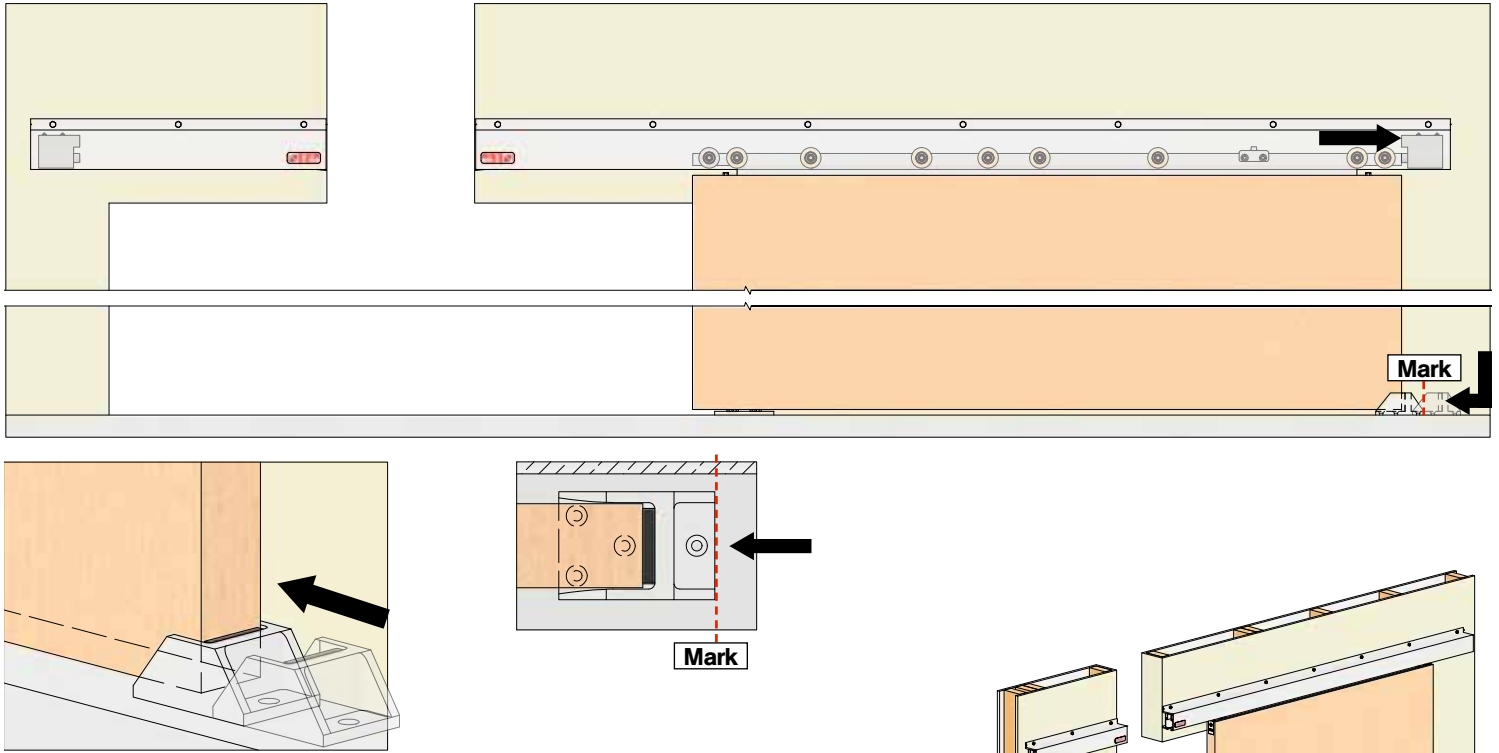

Step #23:

Move door away from CC-101HD Stop, locate C-102HD Floor Stop on marks from **step #22** and secure to floor with four (4) #10 x 1-3/4" Flathead Screws [FT9].

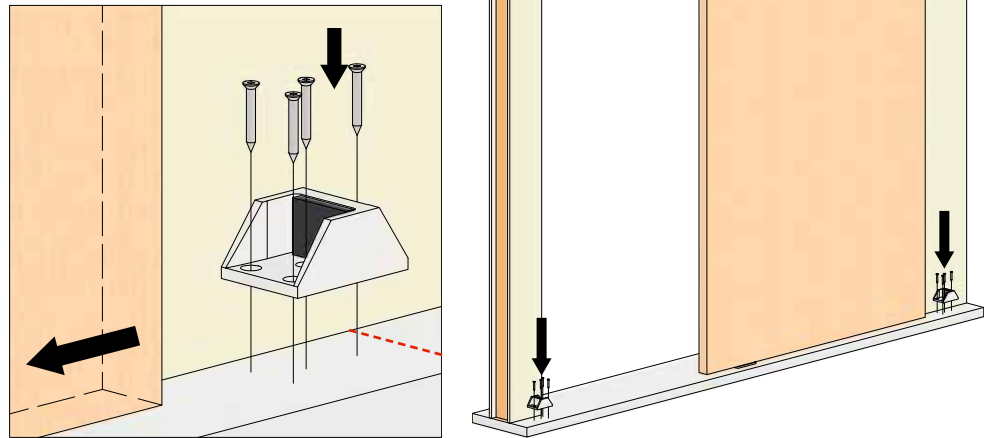

Step #24:

Repeat **step #22 - 23** for strike-side door stop.

Step #25:

Before installing Catch 'N' Close Devices, ensure they are in the retracted position as shown below. If they are not in the correct position, slide the hook downward until it locks into place.

Note: Requires significant finger pressure.

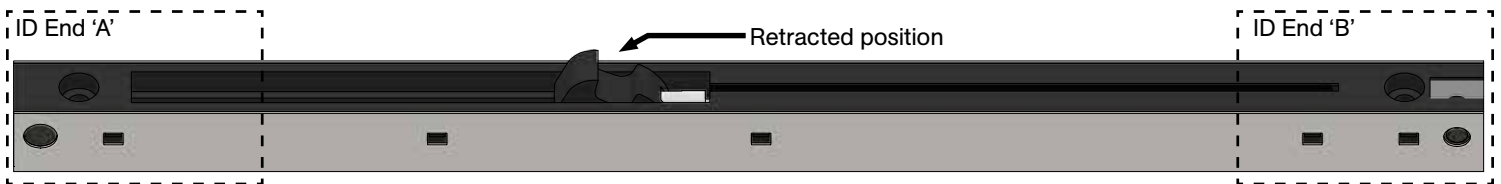

Important Catch 'N' Close Device Notes:

If doors are 200 lbs. [90 kg] or less, ensure CC-2 Catch 'N' Close Devices are used.

If doors are minimum 200 lbs. [90 kg] up to 300 lbs. [136 kg], ensure CC-3 Catch 'N' Close Devices are used.

Step #26:

Position door in closed position against strike-side stops, shown below on left. Place CNC-A Locator Tool (short length) inside track against CC-101HD Stop, shown as right side in these illustrations. While holding the CNC-A Locator Tool in place, position Catch 'N' Close Device into track with leading end 'A' resting against CNC-A Locator Tool.

Note: CNC-A length should not need to be cut down as it is based on Catch 'N' Close trigger installed on CC-820C Cantilever Hanger.

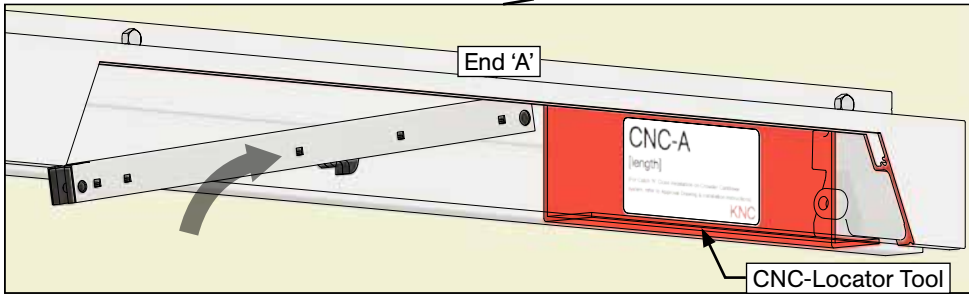
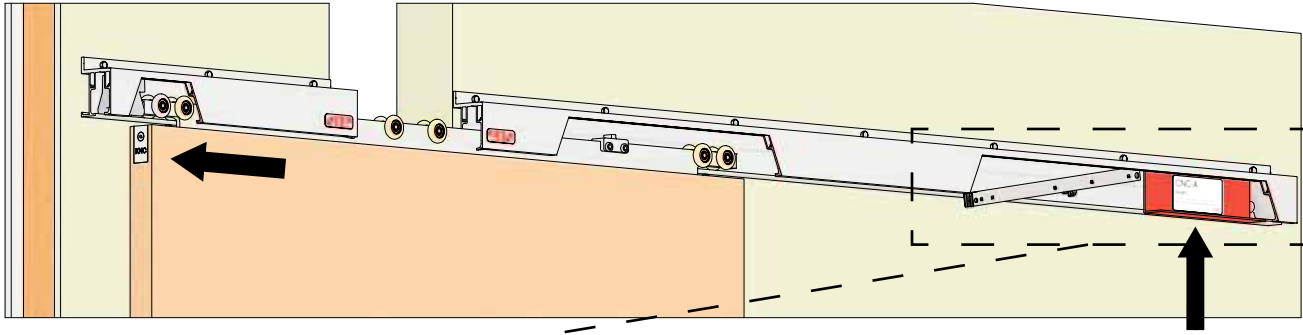

CNC-A Locator Tool x CNC-A

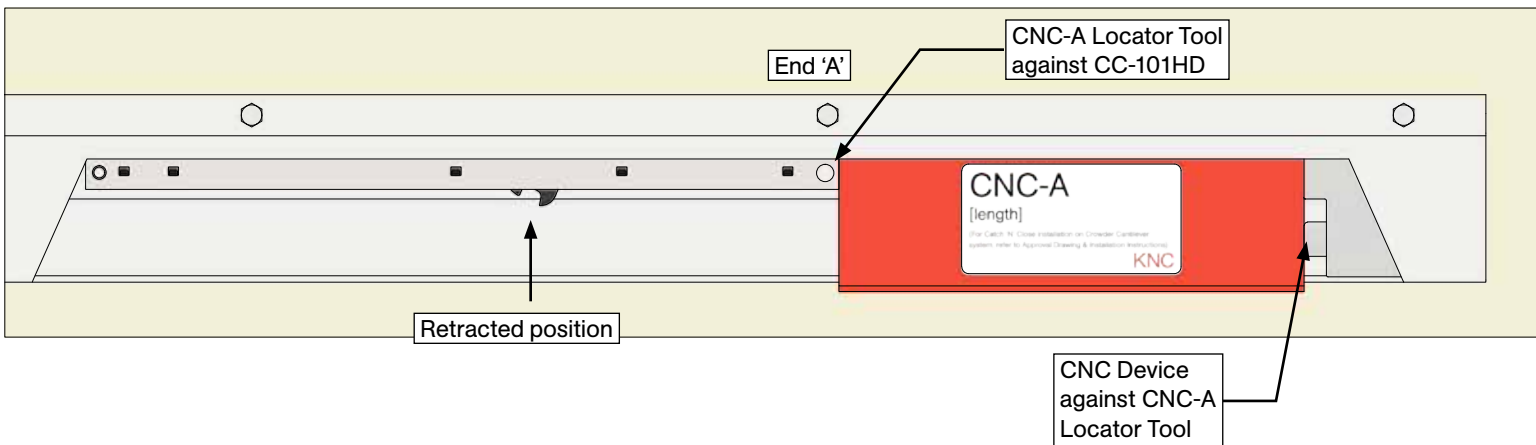
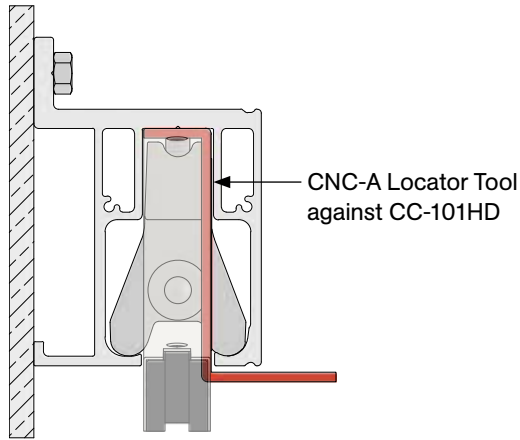
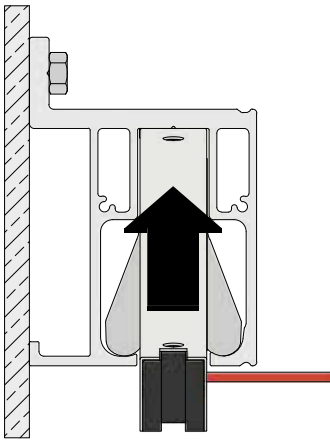

Step #27:

Secure Catch 'N' Close Device to track with two (2) #10 x 1-1/2" Self-Drilling Screws [FT5].

Note: If using impact driver to secure Catch 'N' Close Devices, do not overtighten screws. It is recommended to pre-drill track with Ø9/64 in [3.6 mm] drill bit. Secure first screw closest to CNC-A Locator Tool only, remove Locator Tool from track and test system by sliding door to activate Catch 'N' Close. If in correct position, secure with second screw. Remove any drill fillings from inside track.

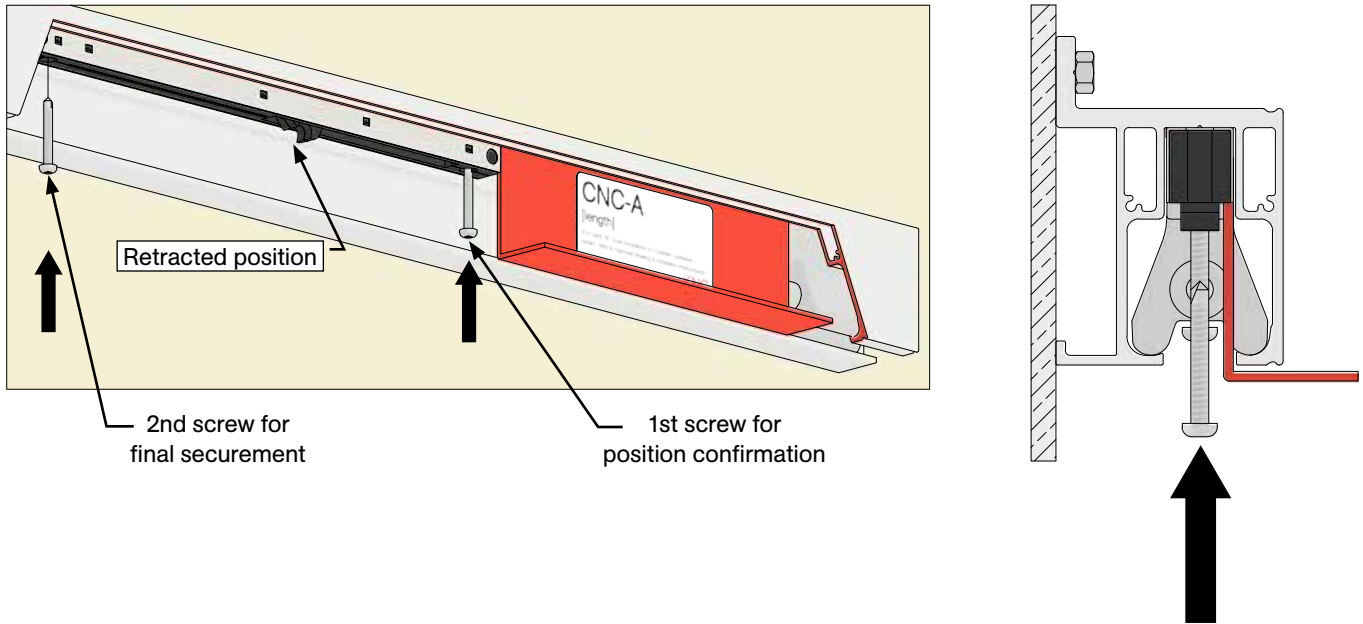

Step #28:

Position door in open position, against right-side stop, as shown below. Insert second Catch 'N' Close device, with end 'B' going into track towards hanger. Position device in upper channel of track and gently rest it on top of hanger for next step.

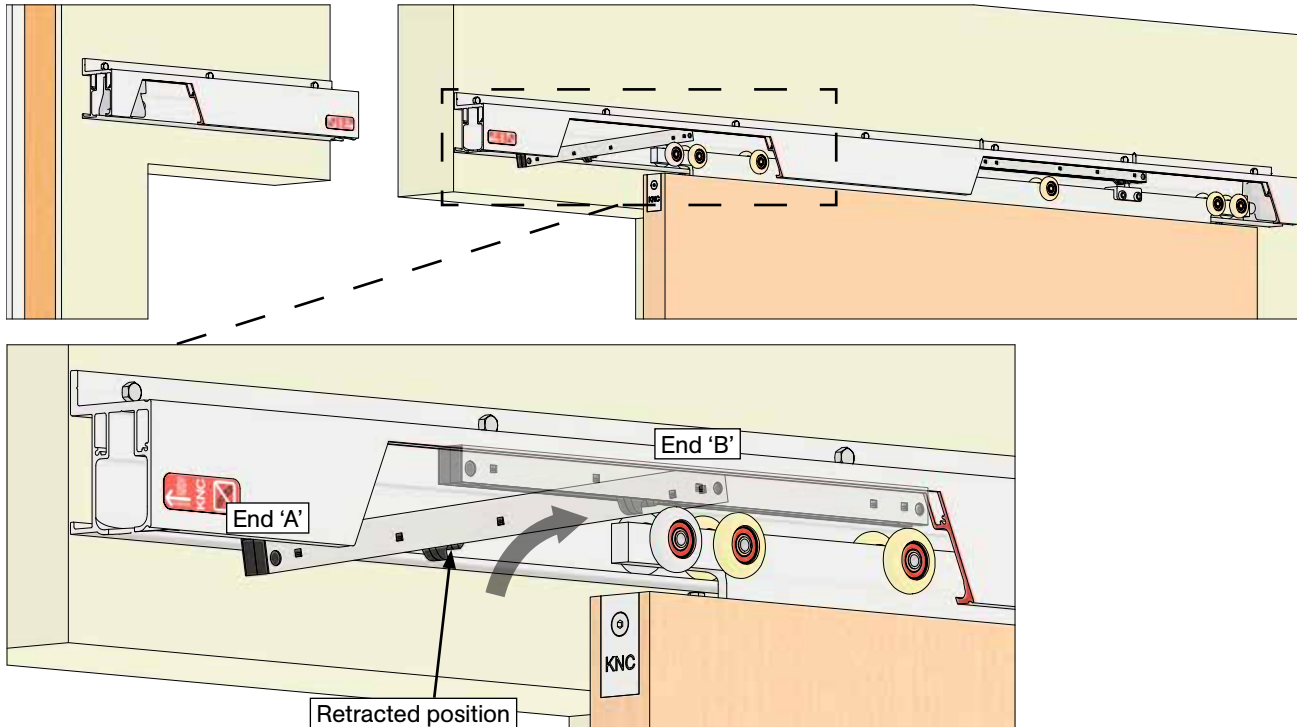

Step #29:

Place CNC-B Locator Tool inside track against strike-side CC-101HD Stop, shown below on left. Hold CNC-B Locator Tool in place and rest end 'A' of Catch 'N' Close Device (from **step #28**) against it.

Note: CNC-B length should not need to be cut down as it is based on Catch 'N' Close trigger installed on CC-820C Cantilever Hanger.

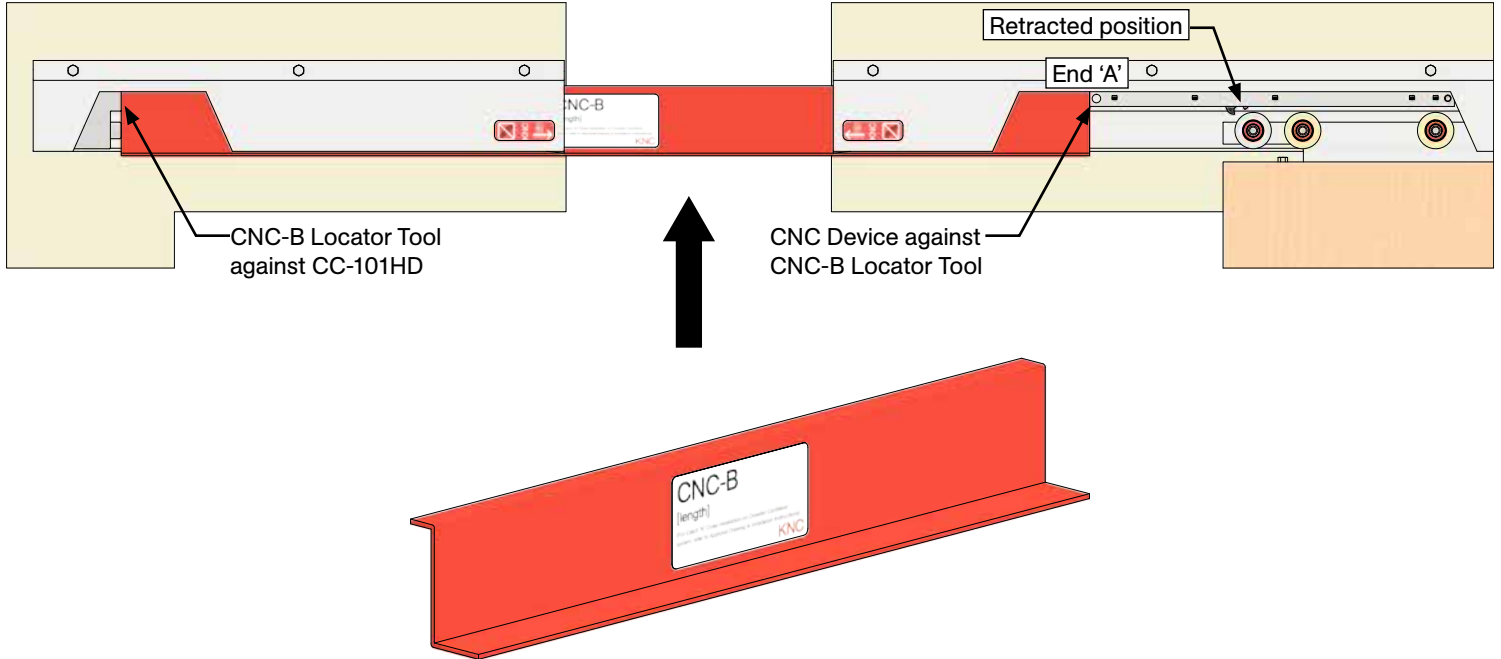

Step #30:

Secure end 'A' of Catch 'N' Close Device to track with one (1) #10 x 1-1/2" Self-Drilling Screw [FT5].

Note: If using impact driver to secure Catch 'N' Close Devices, do not overtighten screws. It is recommended to pre-drill track with Ø9/64 in [3.6 mm] drill bit. Secure this first screw closest to CNC-B Locator Tool only, remove Locator Tool from track and test system by sliding door to activate Catch 'N' Close. Remove any drill fillings from inside track.

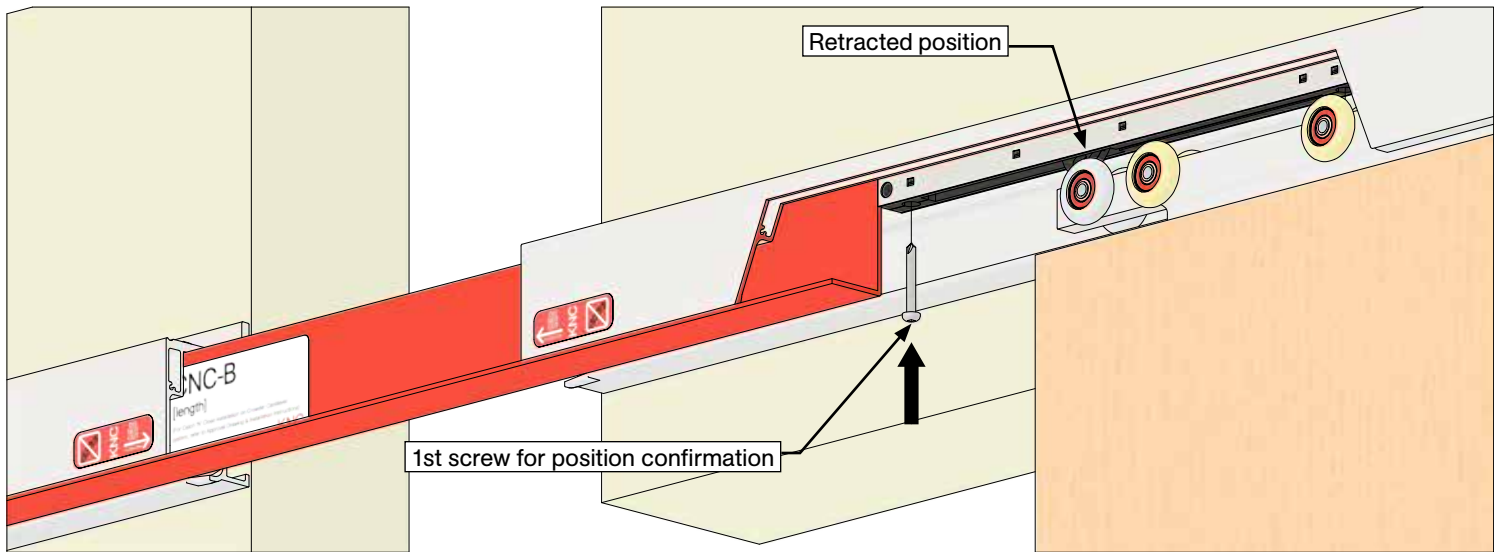

Step #31:

After confirming and securing location of second Catch 'N' Close Device at end 'A', slide door to closed position to expose end 'B' (behind back end of door). Secure end 'B' with one (1) #10 x 1-1/2" Self-Drilling Screw [FT5].

Note: If using impact driver to secure Catch 'N' Close Devices, do not overtighten screws. It is recommended to pre-drill track with Ø9/64 in [3.6 mm] drill bit. Remove any drill fillings from inside track.

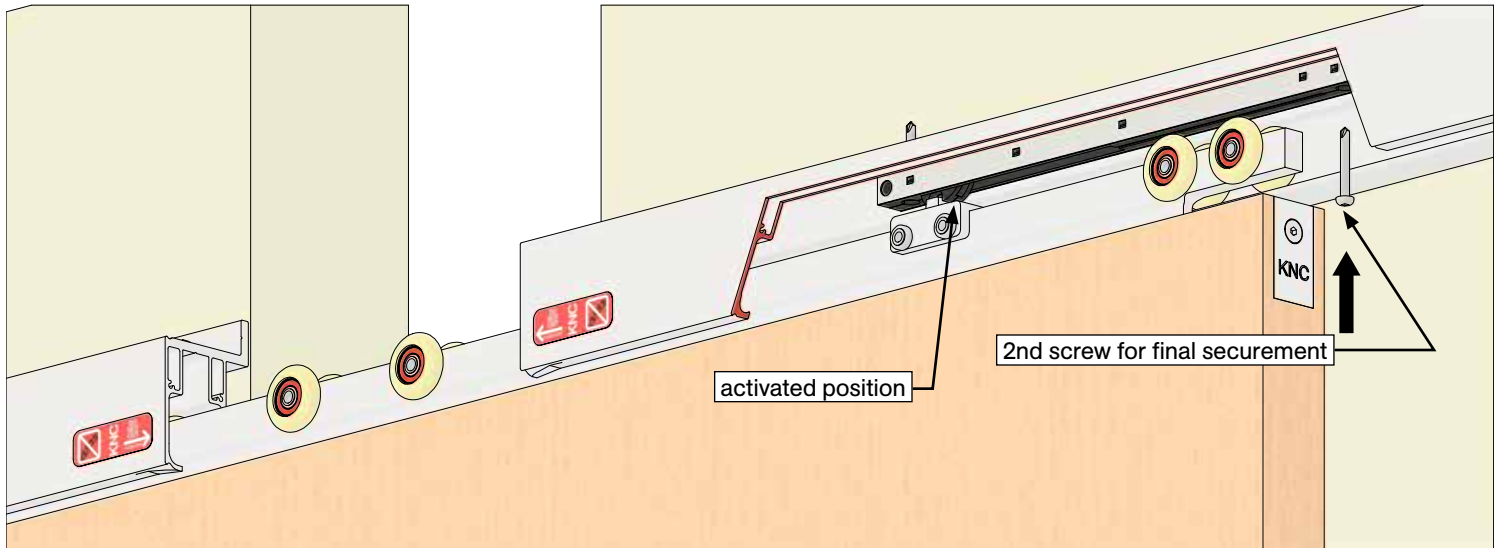
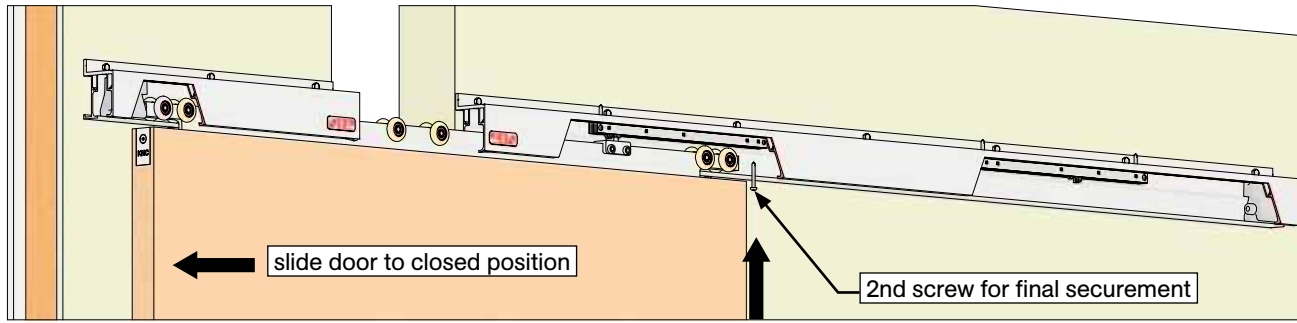

Step #32:

Test complete Catch 'N' Close system by sliding door to both left and right to activate closing devices.

Step #33:

Cut CC-980 Fascias to match the track length.

Step #34:

Lift fascia up to track and snap on as shown below.

Note: If fascia is loose, use a rubber mallet on inside leg at 24 in [610 mm] intervals to tighten fit.

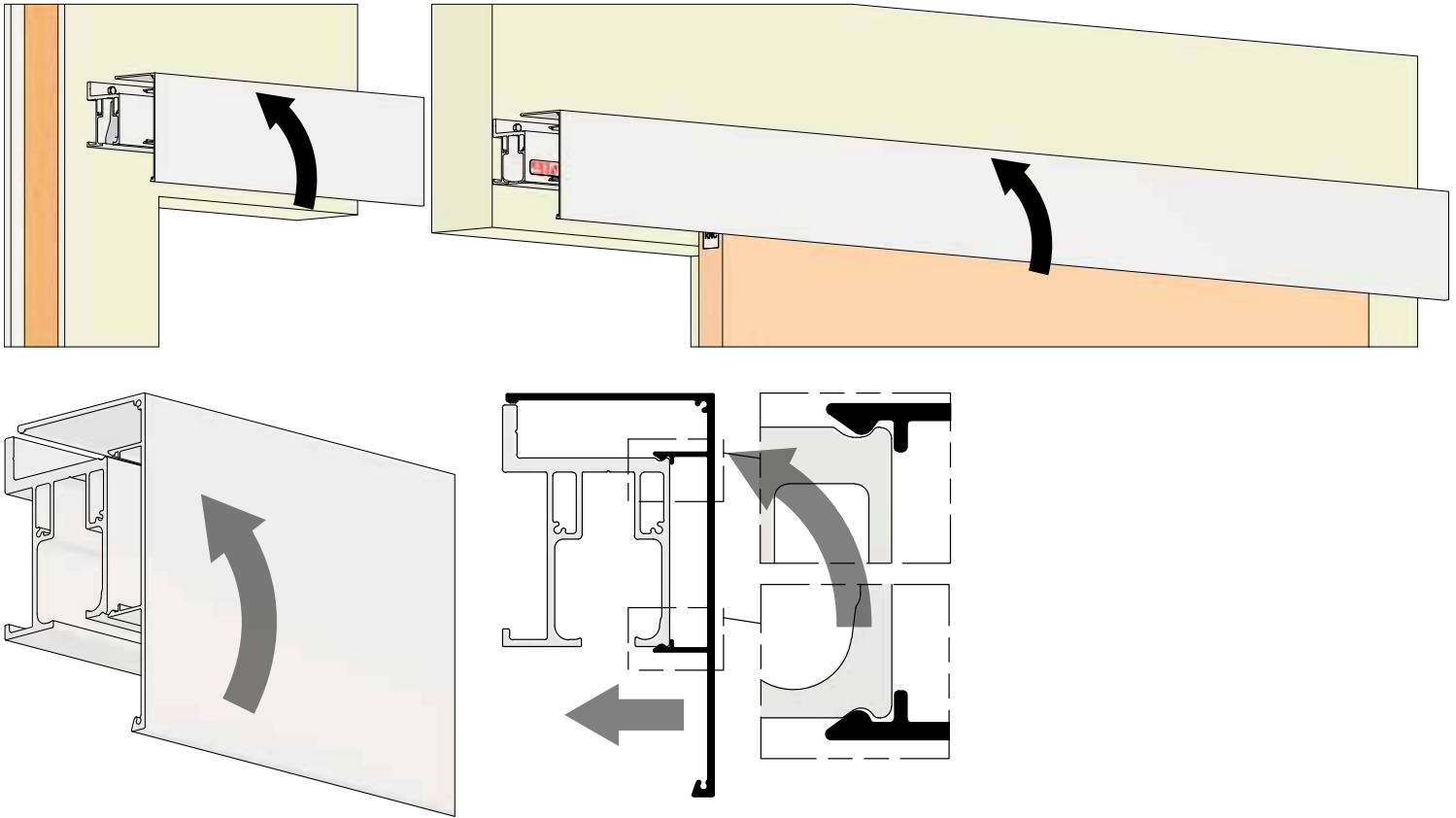

Step #35:

Install CC-981 End Caps and CC-982 Notched End Caps as shown with the supplied #4 x 5/16" Flathead Screws [FT29], four (3) screws per end cap provided.

Note: Do not install with impact driver.

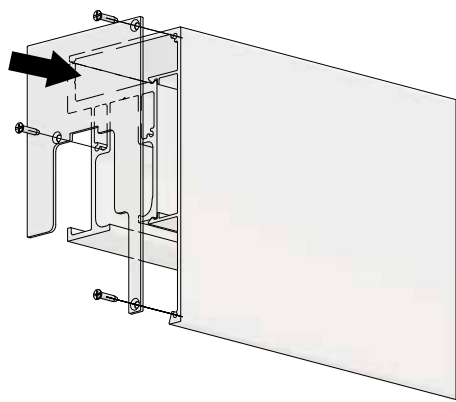
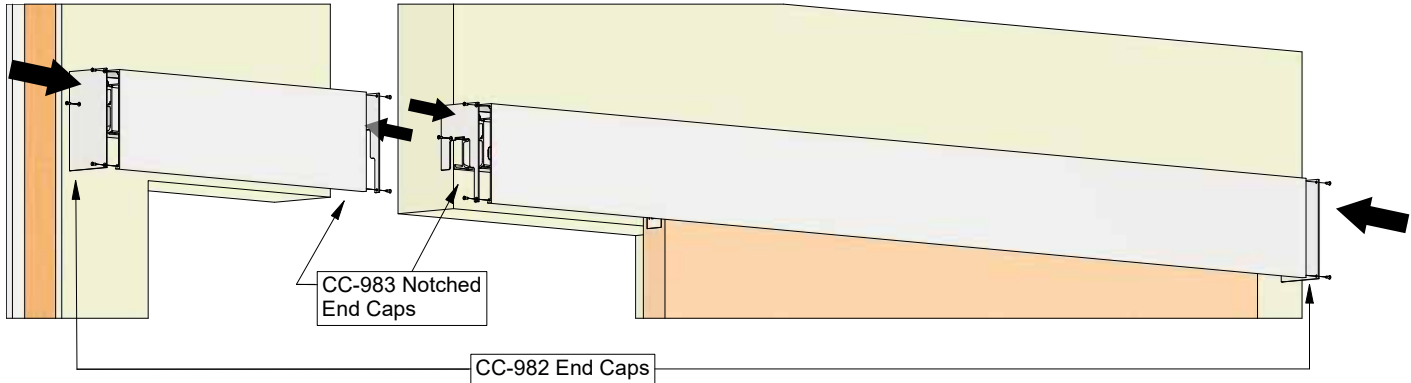

CC-982 Notched End Caps

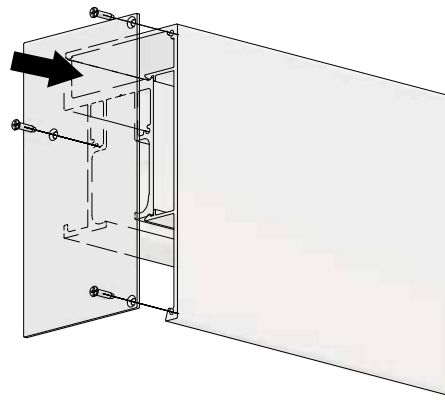

CC-981 End Caps

Troubleshooting

Issue	Solution
Chatter/noise when door is sliding	Ensure there are no aluminum shavings within track. Shavings can become embedded in nylon tires and cause noise during operation.
Door is hard to move	Ensure guide channel secured to bottom of door is not over-tightened as this could cause sides of guide channel to pinch guide. Remove door and check guide channel by rolling guide roller in channel to ensure smooth travel. There should be little to no resistance. Ensure door is not dragging on bottom of floor/guides and adjust height of door as required.
Door rattles	Ensure locking nuts and screws on hangers are secured and not loose.
Door is not engaging closing device	Ensure hangers are correctly oriented. See step #10 . Ensure Catch 'N' Close Devices are in correct retracted or extended position prior to sliding door closed/open. See step #25 .
Replacing the Catch 'N' Close Device	The Catch 'N' Close track and hardware system is designed for easy installation. If a closing device fails, remove the two screws holding it in place and replace the device with a new one.

Alternative Door Installation

if limited space available

If space on both sides of track system is limited and CC-820C Upper Hanger Assembly cannot slide into track as shown in step #10 in general install, the following would need to be carried out to insert CC-820C Upper Hanger Assembly into track and hanging door.

Step #A1:

After securing and leveling tracks as described in **step #3** of general installation (leaving some track securing screws uninstalled as recommended), unfasten CC-908 Flared Track x TRK-A (long length) and remove it from wall to proceed with next steps.

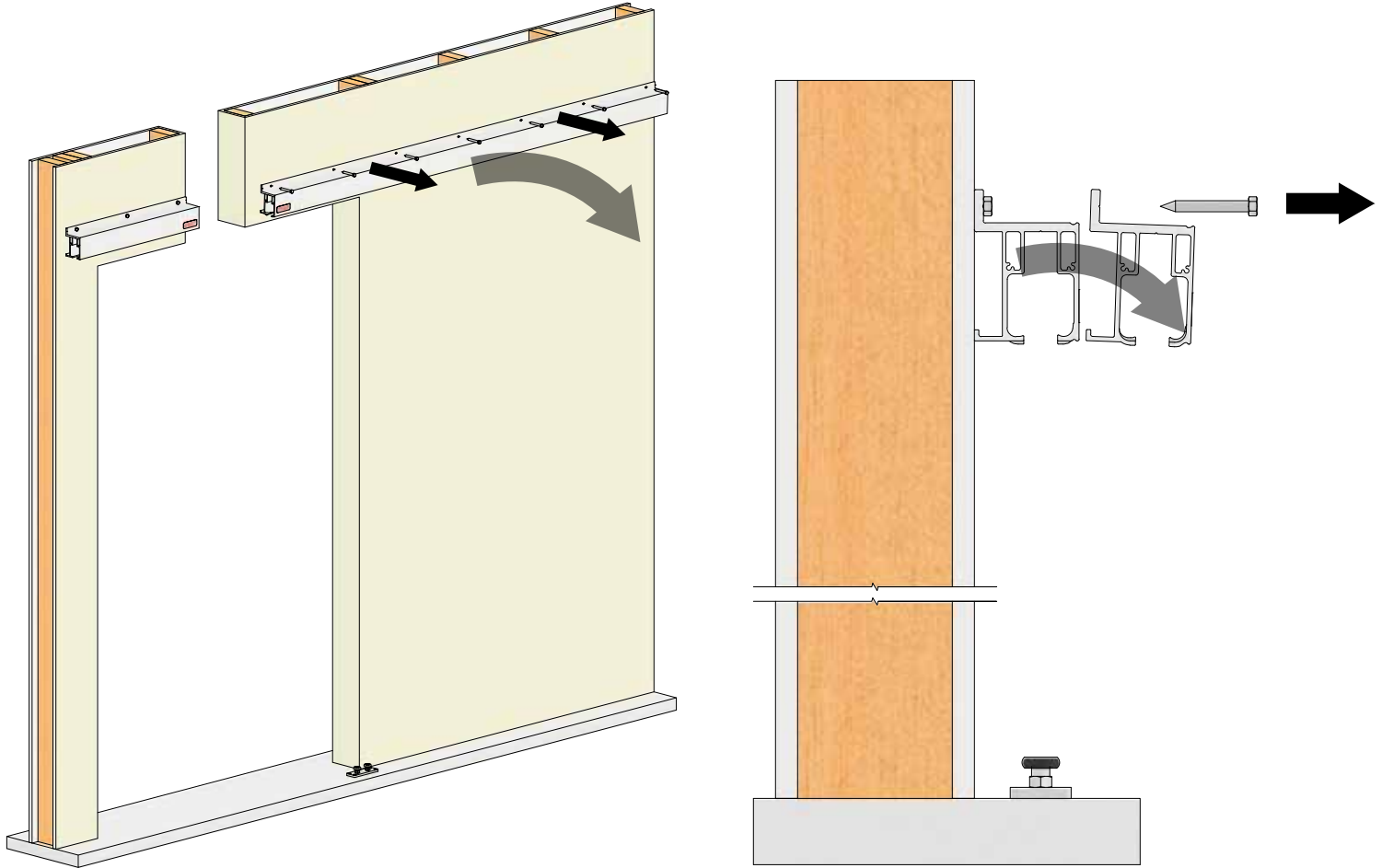

Step #A2:

Insert CC-820C Upper Hanger Assembly into C-821 'U' Housing channel in top of door.

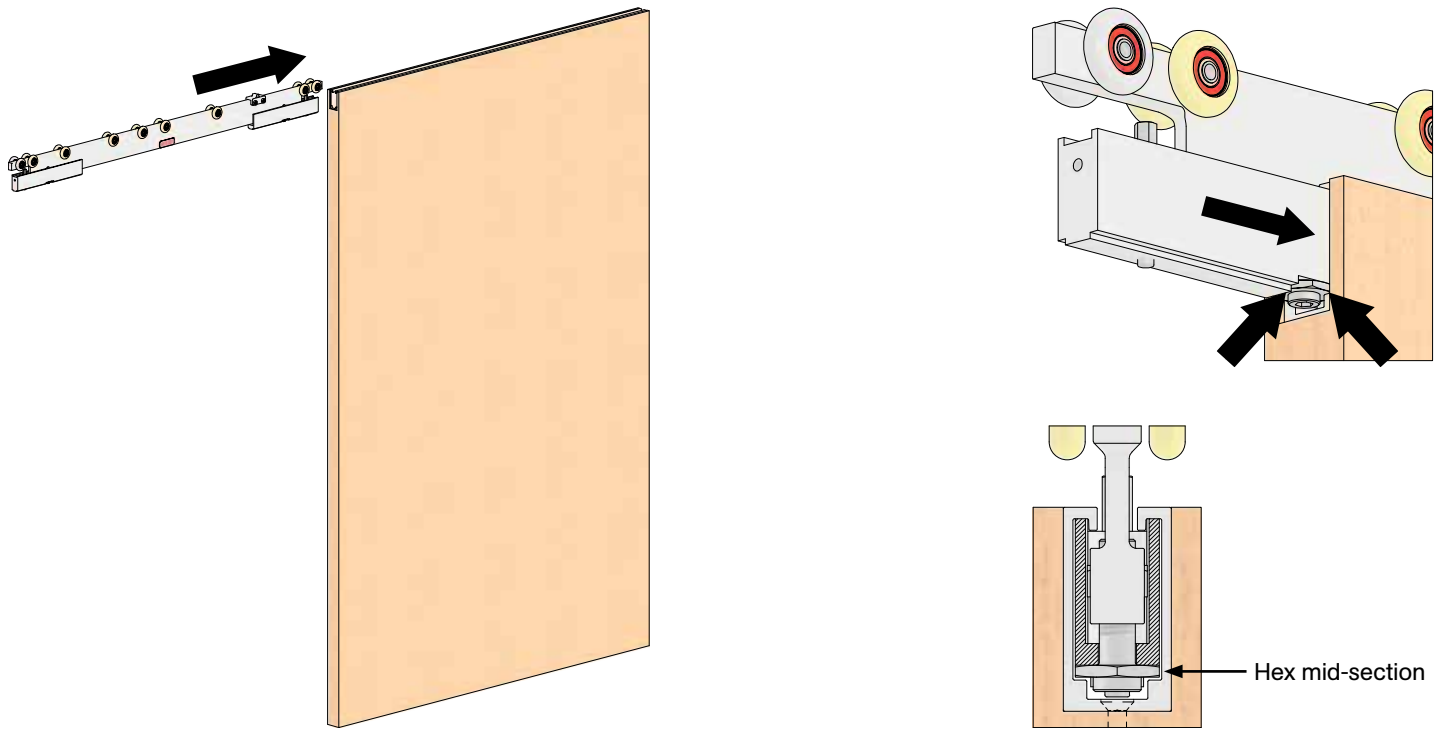

Step #A3:

Slide CC-908 Flared Track x TRK-A (long length) onto hanger, ensuring flared end will align with stainless-steel wheels. If space is limited, insert CC-101HD Stop at back end now (typically done in **step #15** of the general installation).

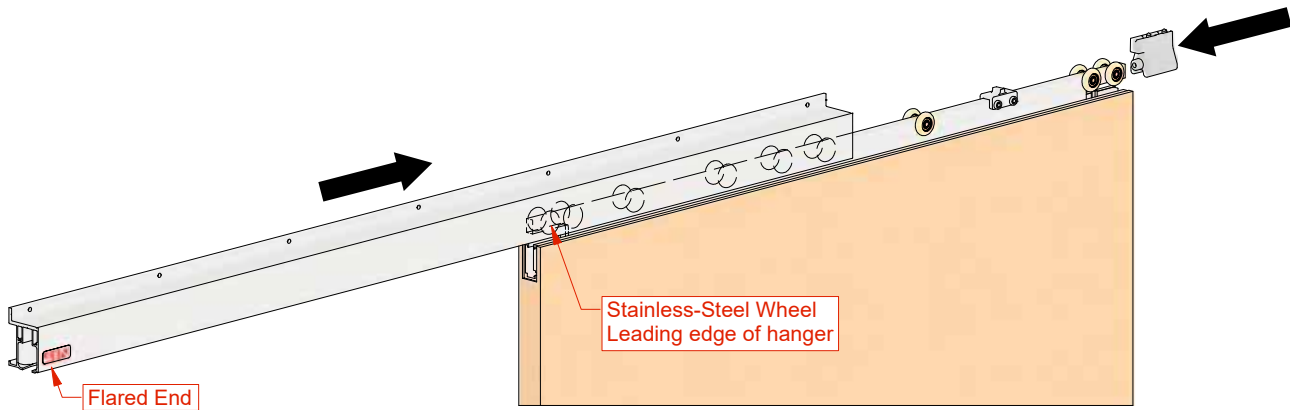

Step #A4:

Raise the door, with upper hanger assembly, track, and stop already attached, and position it over guide.

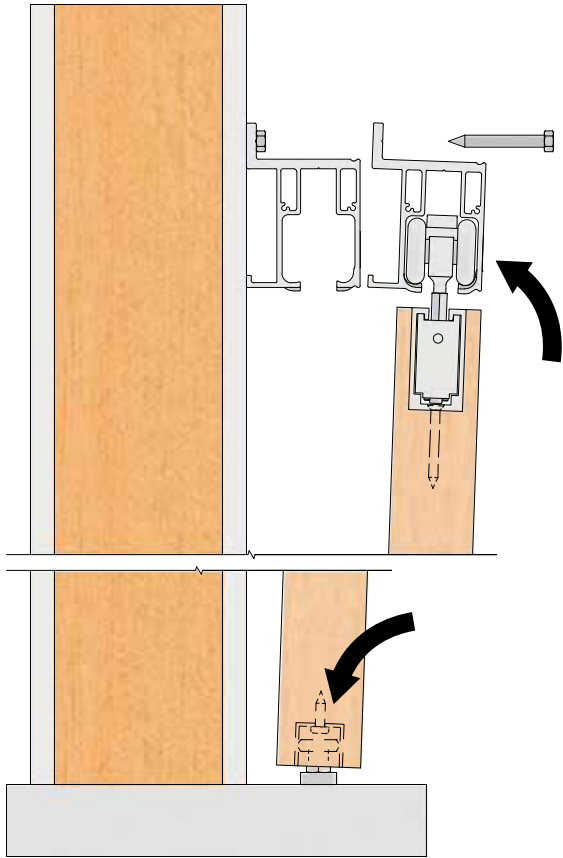

Step #A5:

Re-secure CC-908 Flared Track X TRK-A (long length) to support as per **step #3** in general installation.

Note: It is recommended to place shims or use floor clamps under door to raise track to proper height and ensure alignment with other track, as shown in step #3 of the general installation.

